

UPUTSTVO ZA UPOTREBU

Mašina za vez

Product Code: 882-D80/D82

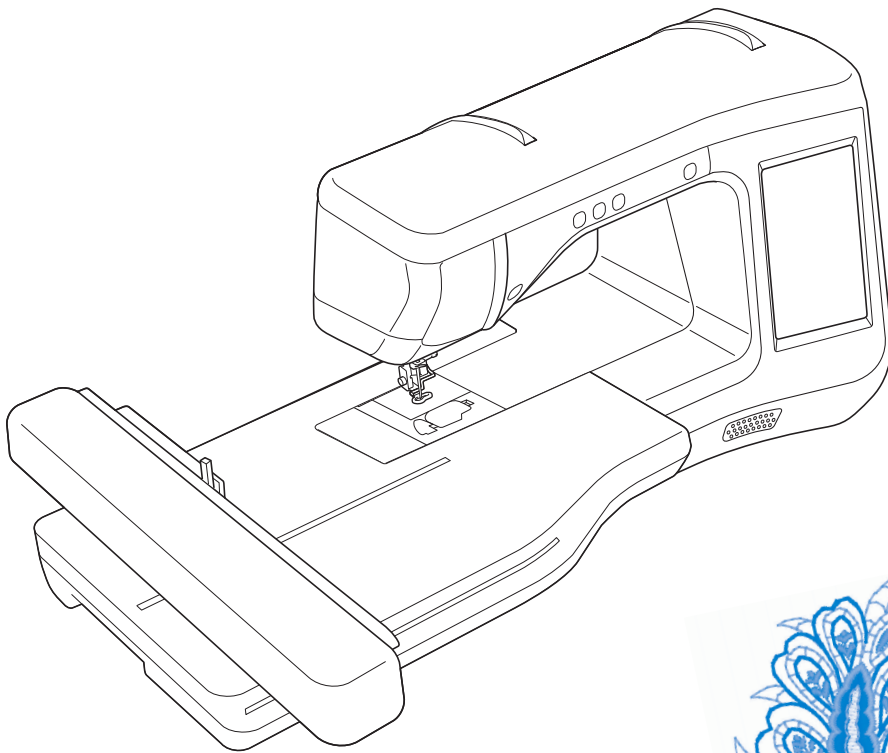

ŠTA MOŽETE DA URADITE SA OVOM MAŠINOM

B

Poglavlje 1:
Priprema

Strana [B-16](#)

Poglavlje 2:
Upotreba funkcija

E VEZ

Poglavlje 1: Vez

Maximum 30 cm x 18 cm

Strana [E-2](#)

Poglavlje 2: Vezni dizajn

Strana [E-56](#)

A DODATAK

Poglavlje 1:
Špulna

Strana [A-2](#)

NAZIVI DELOVA I NJIHOVE FUNKCIJE

MAŠINA

■ Čeona strana

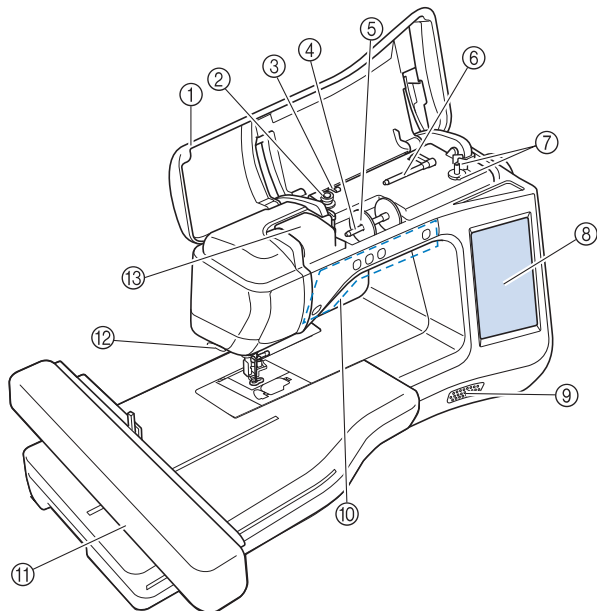

- ① Poklopac
- ② Disk za namotavanje špulne
- ③ Vodilica za namotavanje špulne
- ④ Nosač kalema konca
- ⑤ Držač konca
- ⑥ Dodatni nosač kalema konca
- ⑦ Motač špulne
- ⑧ LCD
- ⑨ Zvučnik
- ⑩ Operacioni tasteri
- ⑪ Vezna jedinica
- ⑫ Sekač konca
- ⑬ Vodilica gornjeg konca

■ Desna strana

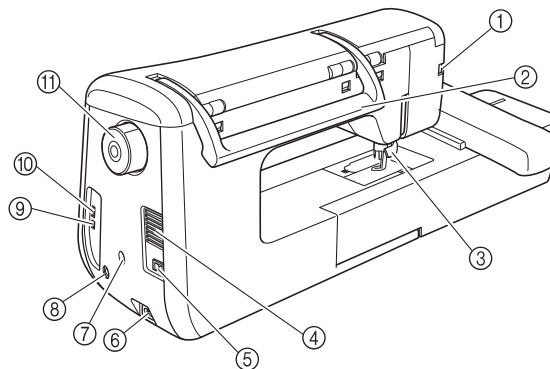

- ① Konektor
- ② Ručka
- ③ Podizač stopice
- ④ Ventilacija
- ⑤ Glavni prekidač
- ⑥ Priključak za kabl
- ⑦ Nosač za senzor olovku
- ⑧ Utikač za senzor olovku
- ⑨ USB ulaz
- ⑩ USB ulaz za miša
- ⑪ Zamajac

IGLA I STOPICA

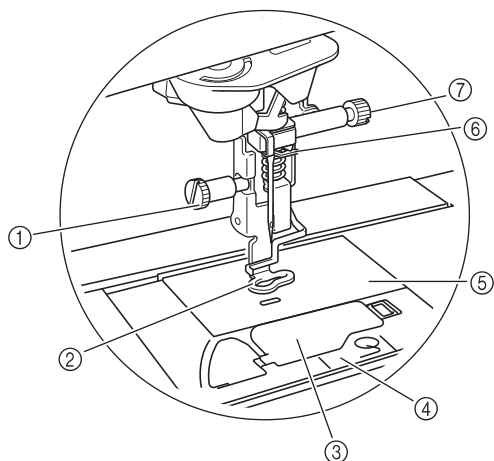

- ① Šraf
- ② Stopica za vez
- ③ Poklopac grajfera
- ④ Poklopac za ubodnu ploču
- ⑤ Ubodna ploča
- ⑥ Držać konca na igli
- ⑦ Šraf za zamenu igle

VEZNA JEDINICA

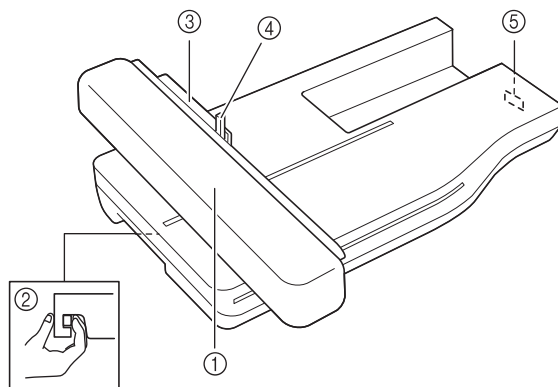

- ① Ruka za vez
- ② Dugme za otkopčavanje
- ③ Držać rama za vez
- ④ Poluga za osiguravanje rama
- ⑤ Ulaz za veznu jedinicu

OPERATIVNI TASTERI

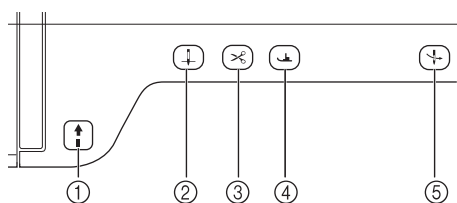

① Start-stop taster 

② Pozicija igle gore-dole 

③ Sekač konca 

④ Podizač stopice 

⑤ Automatsko uvlačenje konca 

PRIBOR

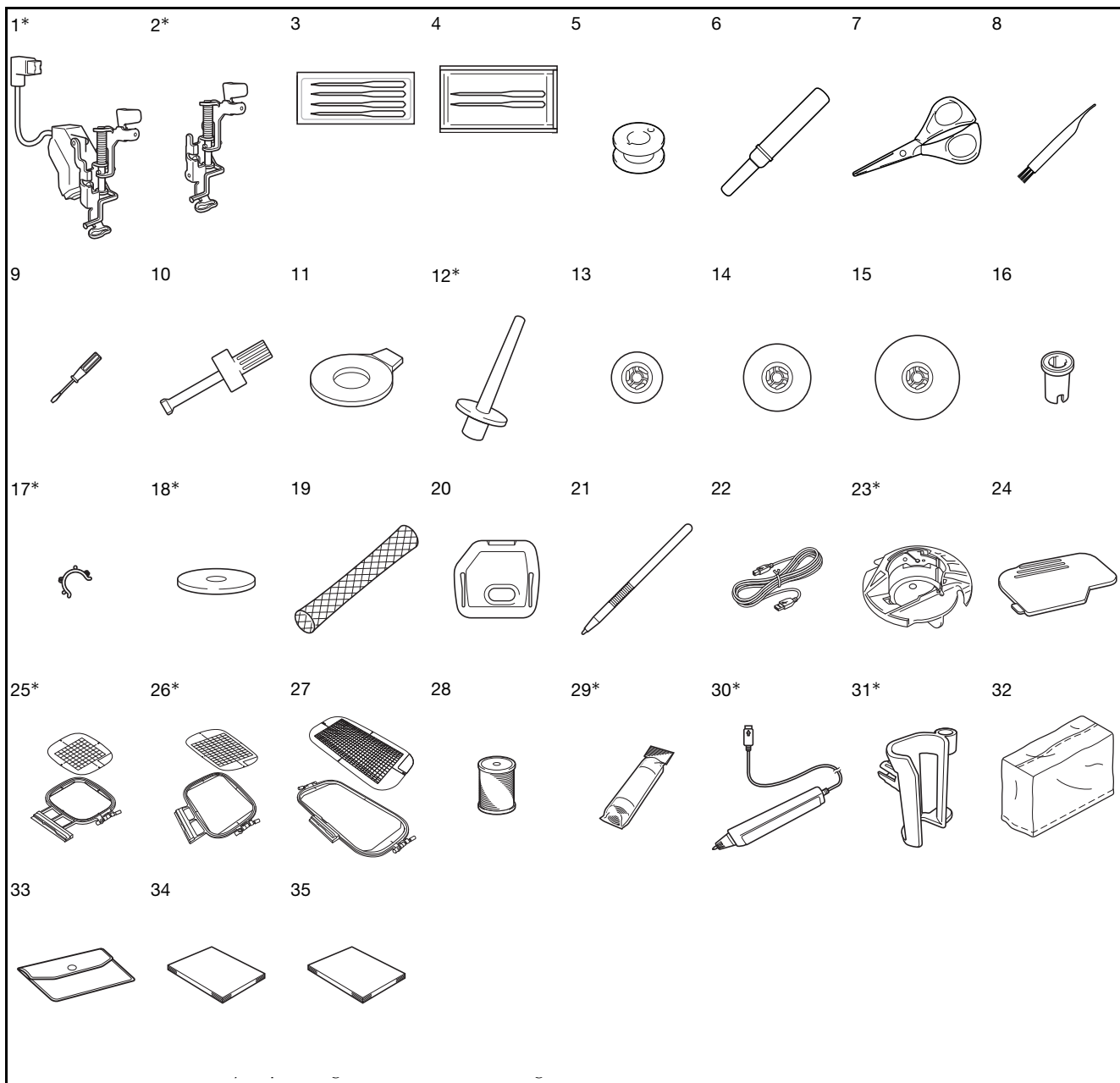

No.	Part Name	Part Code	
		Americas	Others
1	Stopica za vez	FLED1: XF4168-001 (EU area) XF3124-001 (other area)	
2	Stopica za vez	XF4012-001	
3	Igle	X59535-051	
4	Igle	XD0705-051	
5	Špulne x 10	SA156	SFB: XA5539-151
6	Paralica	XF4967-001	
7	Makazice	XC1807-121	
8	Četkica	X59476-051	
9	Mali šrafčiger	X55468-051	
10	Veliki šrafčiger	XC4237-021	
11	Šrafčiger disk	XC1074-051	
12	Vertikalni nosač konca	XC8619-052	
13	Držač konca- mali	130013-154	
14	Držač konca- srednji	X55260-153	
15	Držač konca- veliki	130012-054	
16	Držač konca- specijalan	XA5752-121	
17	Štipalijke za špunu	XE3060-001	
18	Jastučić za konac	X57045-051	
19	Mrežice	XA5523-050	
20	Poklopac	XE5131-001	
21	Olovka	XA9940-051	
22	USB kabl	XD0745-051	
23	Grajer	XE8298-001	
24	Poklopac za grajer	XE8992-101	
25	Ram-srednji	SA438	EF74: XC8480-152
26	Ram-veliki	SA439	EF75: XC8481-152
27	Ram-najveći	SA440	EF76: XC8482-152
28	Konac	EBT-PE	EBT-PEN: XC5996-001
29	Stabilizator	SA519	BM3: XE0806-001
30	Senzor olovka	XF4992-001 (EU area) XF3116-001 (other area)	
31	Držač za olovku	XF2973-001	
32	Pokrivač	XF4569-001	
33	Torbica za pribor	XC4487-021	
34	Uputstvo	This manual	
35	Kratka uputstva	XF3841-001 (882-D80) XF3637-001 (882-D82)	

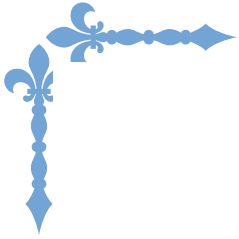

OSNOVNE

OPERACIJE

POGLAVLJE 1

PRIPREMA

Uključivanje i isključivanje mašine	17
Podešavanje mašine prvi put	18
LCD Ekran.....	20
■ Prva strana ekrana.....	20
■ Operativne funkcije.....	21
Upotreba podešavanja mašine.....	22
■ Odabir “Eco Moda” ili “Podrška za isključivanje Moda”.....	25
■ Promene kada je uključen miš	25
■ Odabir inicijalnog ekrana	25
■ Odabir jezika.....	26
■ Promena boje pozadine.....	26
■ Precizirajte veličine sličice dizajna	27
■ Čuvanje podešavanja ekrana na USBu.....	28
Upotreba pomoćnih funkcija	29
DONJI KONAC	31
Namotavanje špulne.....	31
■ Korišćenje dodatnog nosača konca.....	31
■ Upotreba nosača konca.....	34
■ Raspetljavanje konca	35
Nameštanje špulne	36
GORNJI KONAC.....	38
Uvlačenje gornjeg konca.....	38
Upotreba konca koji se brzo odmotava.....	41
■ Korišćenje mrežice	41
Promena stopice za vez.....	42
Sklanjanje stopice.....	42
Postavljanje stopice.....	42
■ Provera uboda igle	43
■ Podešavanja na ekranu	44
■ Podešavanja svetlosti na ekranu	44
Zamena igle	45
O iglama.....	46
PRE VEZA.....	46
Vez korak po korak	46
O veznoj jedinici.....	47
■ Sklanjanje vezne jedinice	47
■ Postavljanje vezne jedinice	47
Upotreba funkcija pri upotrebi dodatnog pribora	49
Upotreba USBa ili kartice.....	49
Priključivanje mašine na kompjuter.....	49
Upotreba miša	50
■ Zaključavanje	50
■ Promena strane	50

1 Stavite utikač u utičnicu

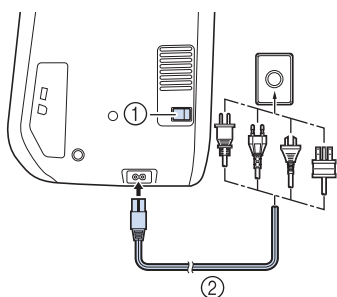

- ① Prekidač
- ② Ulaz za utičnicu

2 Uključite mašinu

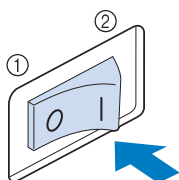

- ① OFF
- ② ON

3 Kada uključite mašinu, počće početni video, pa pritisnite bilo gde na ekran, da biste isli na glavni meni.

4 Kada isključujete mašinu, prekidač nameštite na "o".

Podešavanje mašine prvi put

Kada mašinu uključujete prvi put, izaberite jezik i vreme i datum u skladu sa lokalnim podešavanjima. Pratite uputstva dalje.

1 Pritisnite i da izaberete jezik

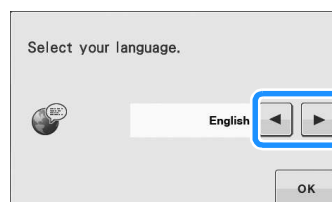

2 Zatim .

3 Poruka na ekranu će morati da se potvrdi sa ok, ukoliko želite dalje da podešavate datum i vreme. a ukoliko ne želite pritisnite cancel.

4 Pritisnite  ili  za podešavanje vremena i datuma

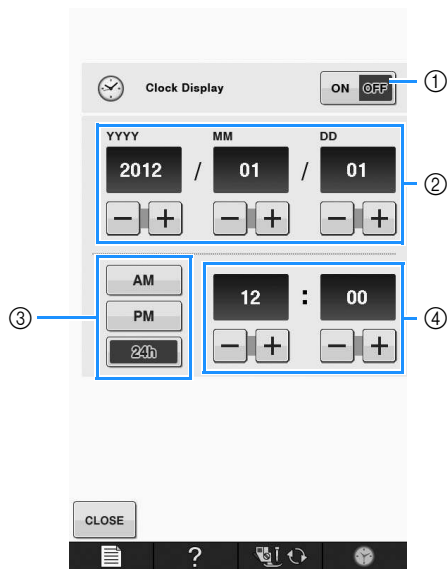



- ① pritisnite da bi se pokazalo vreme na ekranu
- ② namestite godinu, mesec i dan
- ③ namestite na 24h ili 12h
- ④ postavite sadašnje vreme

5 Pritisnite  da biste mogli da počnete da koristite mašinu

EKRAN

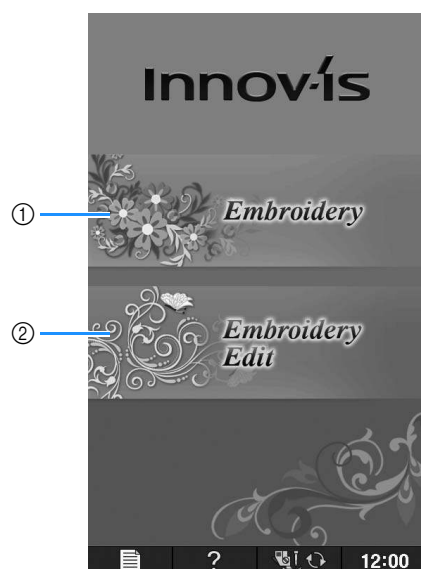



■ Početna strana

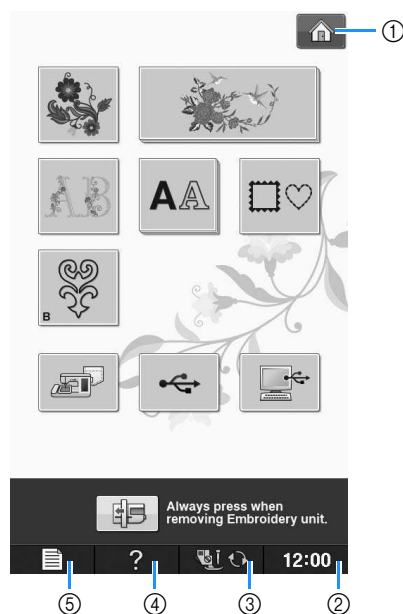

①		Vež	Prikačite veznu jedinicu i pritisnite ovaj taster za dizajn veza
②		Podešavanje veza	Ovaj taster pritisnite za kombinovanje i podešavanje veza

■ Funkcije



①		Početna strana	pritisnite kada želite da se vratite na početak	B-20
②		Sat	za podešavanje vremena	B-18
③		zamena stopice i igle	pritisnite ako menjate stopicu ili iglu, da zaključate mašinu	B-42 to B-45
④		Pomoć	pritisnite za pojašnjenja u vezi sa mašinom	B-29
⑤		Podešavanja	pritisnite ako želite da menjate podešavanja	B-22

PODEŠAVANJA

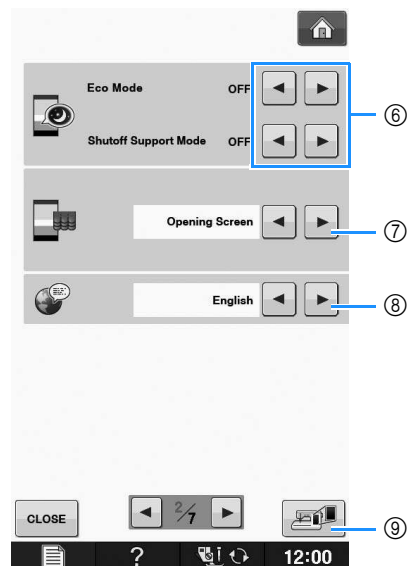
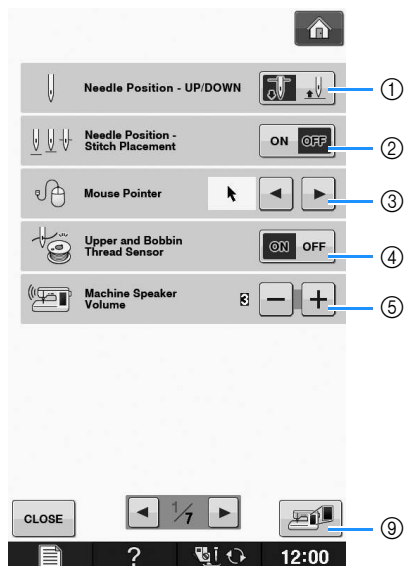

- ① odaberite da li želite da igla završava dole ili gore
- ② odaberite poziciju igle i jednu od dve sekvence.
ON- igla se podiže, zaustavi blizu tkanine, a zatim se spušta
OFF- igla se podiže i nakon toga spušta
- ③ promenite oblik prikaza miša
- ④ uključite senzor za gornji konac.
kada je senzor uključen, mašina ne može da radi bez gornjeg konca
- ⑤ promenite jačinu zvuka
- ⑥ odaberite mod u kome želite da mašina radi
- ⑦ odaberite inicijalni ekran koji se prikazuje kada se mašina uključi
- ⑧ odaberite jezik
- ⑨ sačuvajte podešavanja na USBu

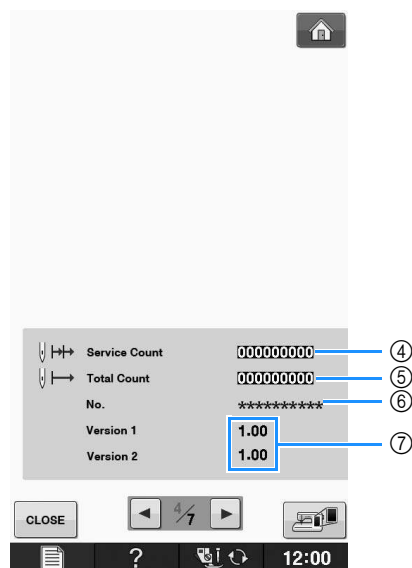
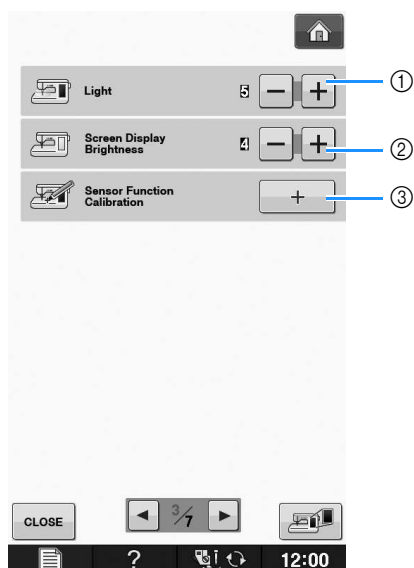

- ① podešavanje svetlosti radne površine
- ② podešavanje svetlosti ekrana
- ③ kalibriranje senzorskih funkcija
- ④ brojač servisa
posetite servisera kada je to potrebno, da bi mašina imala duži vek.
- ⑤ brojač bodova
- ⑥ interni broj mašine
- ⑦ izaberite verziju ekrana
1- prikazuje programsku verziju ekrana
2- prikazuje programsku verziju mašine

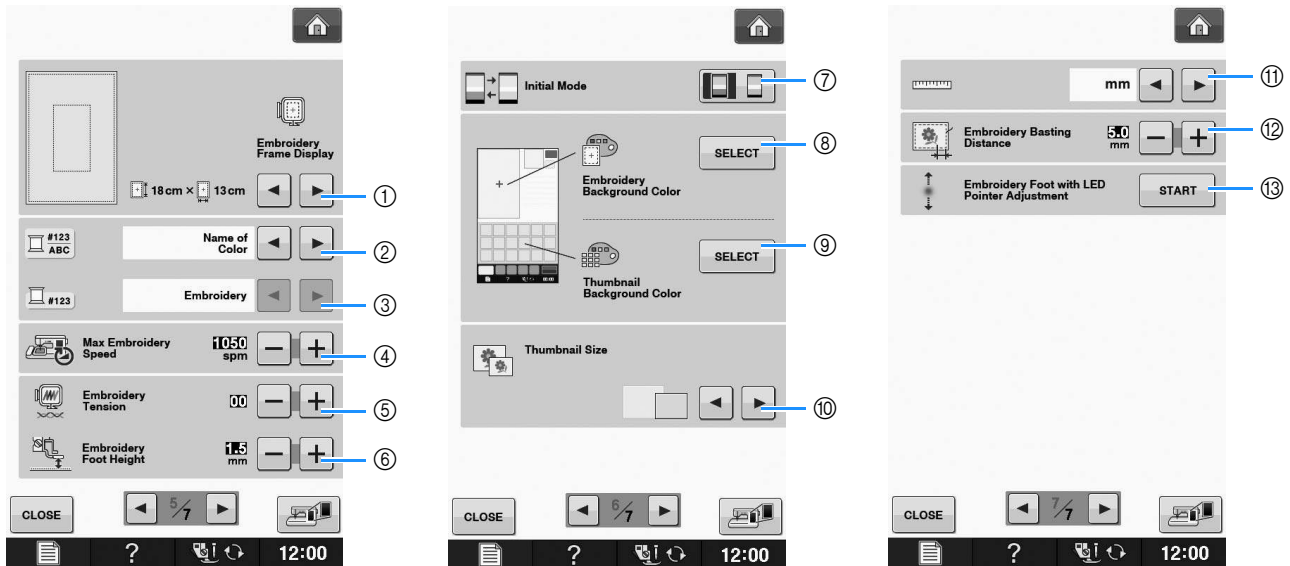

- ① izaberite ram
- ② promenite boju, broj i ime konca
- ③ izaberite jedan od 6 ponuđenih brendova konca
- ④ podešavanje maksimalne brzine veza
- ⑤ podešavanje napetosti gornjeg konca
- ⑥ podešavanje visine stopice
- ⑦ promena inicijalnog moda
- ⑧ promena pozadine za vez
- ⑨ promena pozadine za ikone
- ⑩ preciziranje veličine ikonica
- ⑪ promena jedinice mere
- ⑫ podešavanje razmaka između dizajna i bodova firca
- ⑬ podešavanje pozicije stopice za vez, uz pomoć Led pokazivača

PODEŠAVANJE MODA RADA MAŠINE



“Eco Mode”;

Mašina će ako ne radi dase "uspava". Na taj način štedite energiju i pipnite bilo gde ekran da se ponovo pokrene rad.

“Shutoff Support Mode”;

Mašina će da se ugasi onida kada namestite vreme.

Pritisnite start-stop taster ili dodirnite ekran, da se vratite na podešavanje moda.



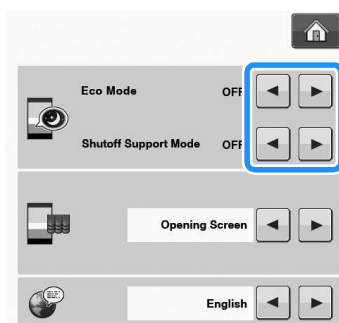



- 1  kada pritisnete ovaj taster, podešavanja će se pojaviti.
- 2 prikazaće se strana 2 sa podešavanjima
- 3 Ovaj  ili  znak će vam pomoći da izaberete vreme ulaska u mod.





PROMENE KADA JE UKLJUČEN MIŠ

B 1

Getting Ready

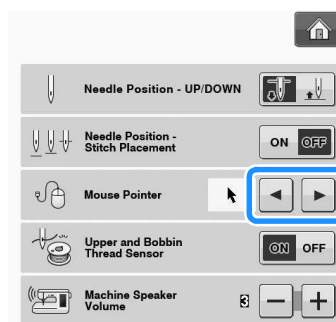
- 1  Kada pritisnete ovaj taster, podešavanja će se pojaviti
- 2 prikazaće se strana 1 sa podešavanjima
- 3  ili  da izaberete jedan od tri oblika (,  ili ).





- 4  ukoliko želite da se vratite na početni ekran

ODABIR INICIJALNOG EKRANA

- 1  taster za podešavanja
- 2 strana 2 sa podešavanjima

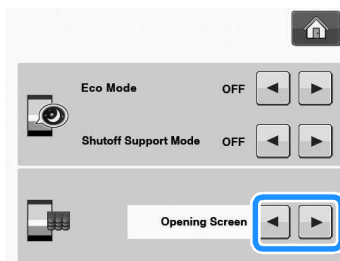
3   strelice za odabir podešavanja



4  da se vratite na početni ekran

ODABIR JEZIKA

1  .
podešavanja

2 strana dva

3  
koristite strelice za odabir jezika

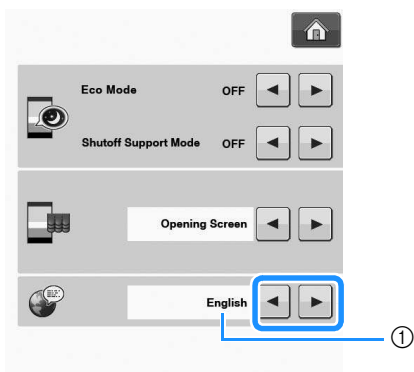

① jezik

4  da se vratite na početni ekran

PROMENA POZADINE DIZAJNA VEZA

1  .
podešavanja

2 strana 6

3 pritisnite  .

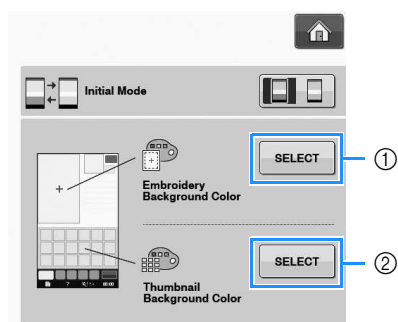

① pozadina veza

② pozadina ikonica

4 izebrite jednu od 66 ponuđenih pozadina

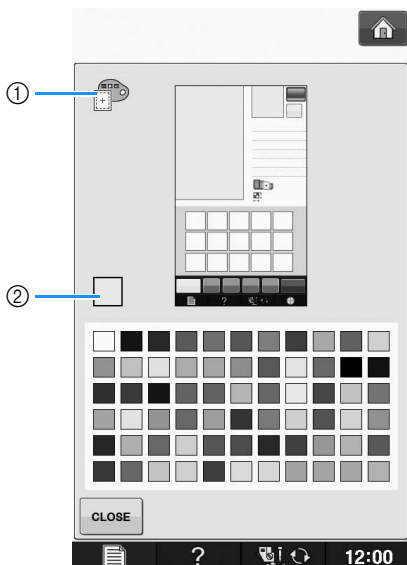

① pozadina
② izabrana boja

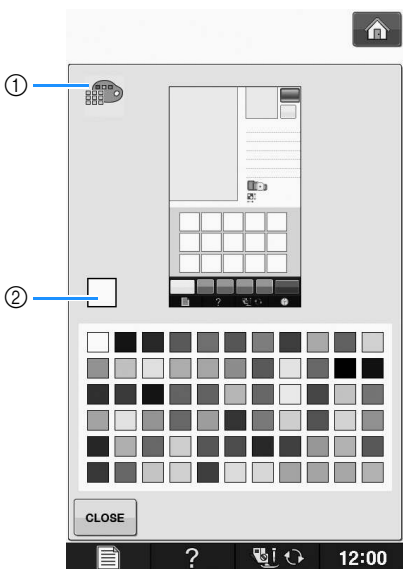

① pozadina ikona
② izabrana boja

5 da se vratite na početni ekran

DIMENZIJE IKONICE

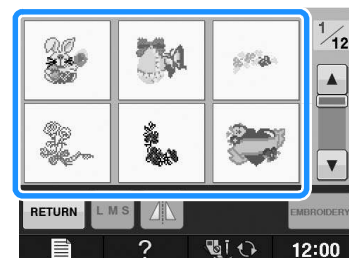
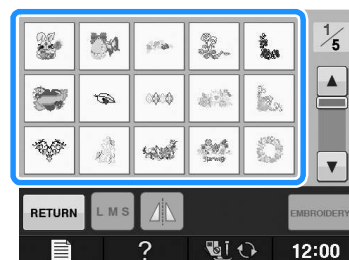

1 .
podešavanja

2 zatim strana 6

3 strelice za odabir željene veličine

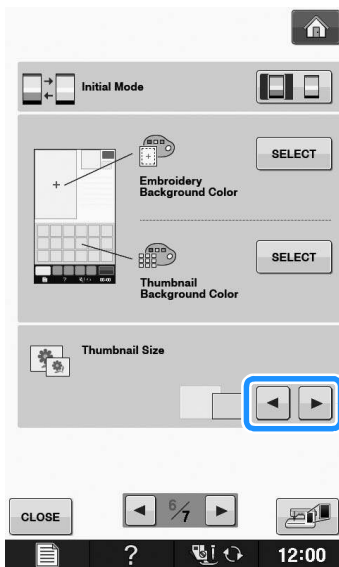

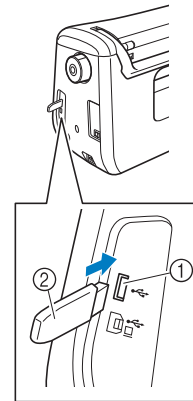

■ ČUVANJE PODEŠAVANJA EKRANA NA USBu

1 ubacite USB



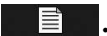

- ① ulaz
- ② USB

2  .
izaberite podešavanja koja želite da sačuvate

3  . pritisnite
i sačuvajte sliku sa podešavanjima na USBu

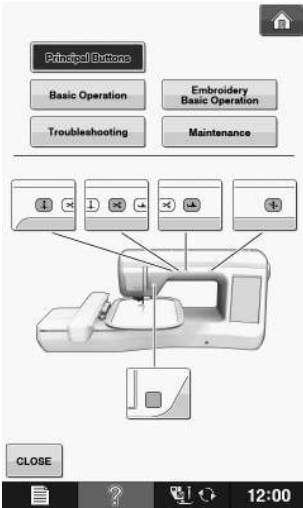
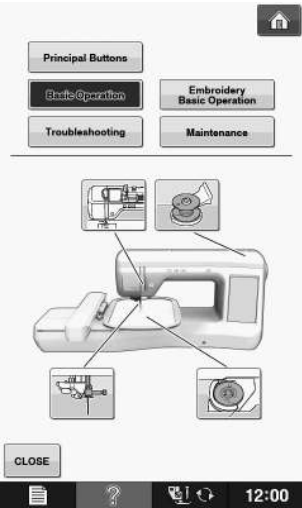
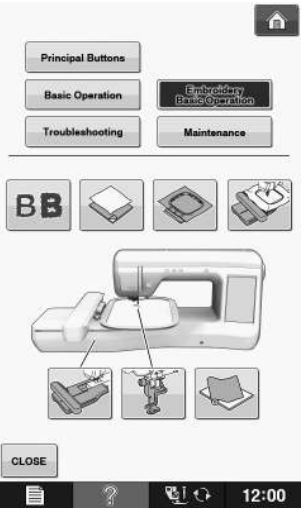
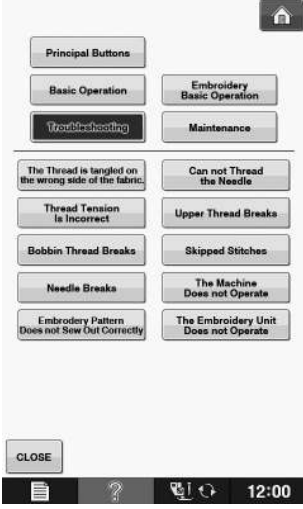
4 uklonite USB i na kompjuteru proverite da li je čuvanje bilo uspešno

 <p>Principal Buttons</p> <p>informacije o operativnim tasterima</p>	 <p>Basic Operation</p> <p>informacije o uvlačenju konca</p>	 <p>Embroidery Basic Operation</p> <p>informacije o veznoj jedinici</p>
 <p>Troubleshooting</p> <p>informacije o problemima</p>	 <p>Maintenance</p> <p>informacije o čišćenju</p>	

Primer: Gornji konac

1 pritisnite .

2 pritisnite .

donja strana ekrana ce se promeniti

3 pritisnite  (**upper threading**).

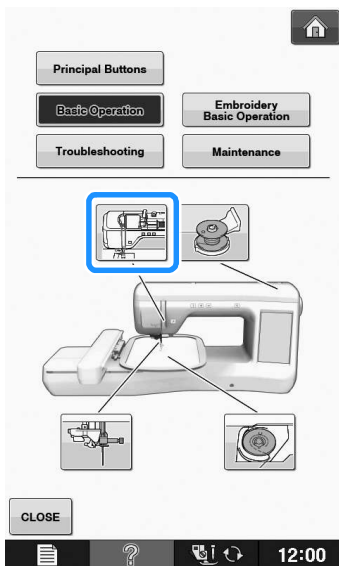

na ekranu se prikazuju instrukcije

4 pročitajte instrukcije

5  da se vratite na početni ekran

DONJI KONAC

NAMOTAVANJE ŠPULNE



! UPOZORENJE

- Koristite isključivo špulne koje su namenjene za vašu mašinu

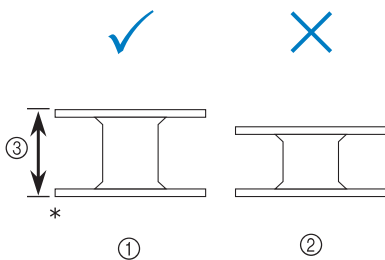

- ① ovaj model
- ② drugi modeli
- ③ 11.5 mm (approx. 7/16 inch)

■ UPOTREBA DODATNOG NOSAČA KONCA

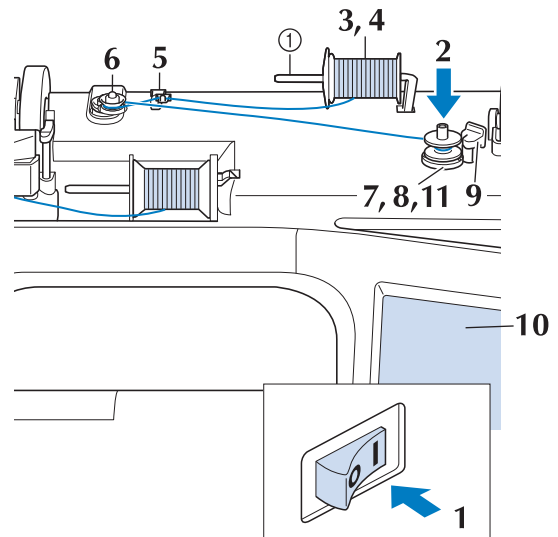

① dodatni nosač

- 1** Uključite mašinu i otvorite poklopac
- 2** izjednačite udubljenje na špulni sa oprugicom na nosaču špulne

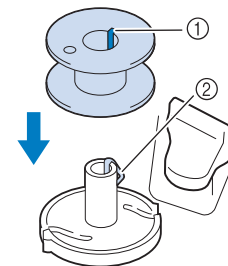

① udubljenje
② oprugica

3 Postavljanje nosača konca u gornju poziciju

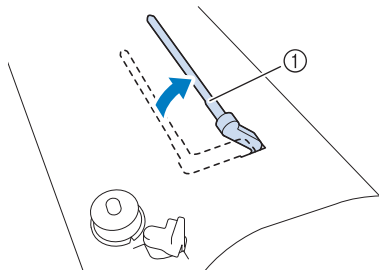

① nosač konca

4 namestite kalem konca na nosač, tako da se odmotava kao na slici.

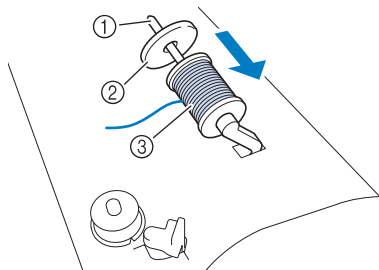

① nosač
② držač kalema
③ konac

NAPOMENA

Kada koristite finije konce, upotrebite manji držač i neka razmak bude mali

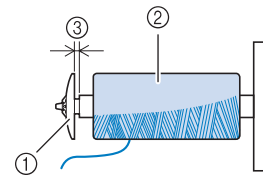

① mali držač
② konac
③ razmak

• u retkim situacijama, koristite i specijalan držač ukoliko je to neophodno

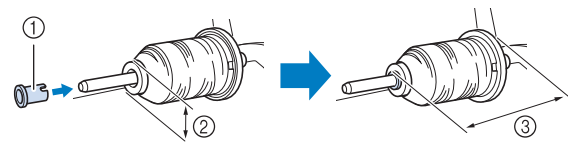

① specijalan držač
② 12 mm (1/2 inch)
③ 75 mm (3 inches)

5 desnom rukom pridržavajte konac, a levom provucite kroz vodilicu konca

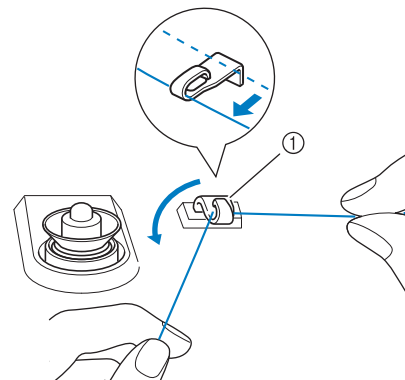

① vodilica

- 6** provucite konac kroz disk za tenziju

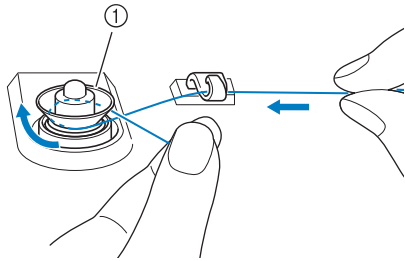

① disk

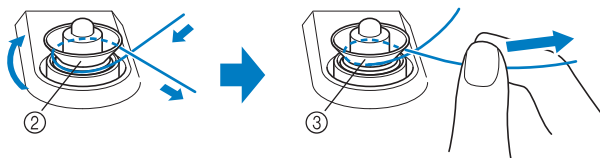

② disk

③ povucite onoliko koliko je moguće

- 7** namotajte konac 5,6 puta

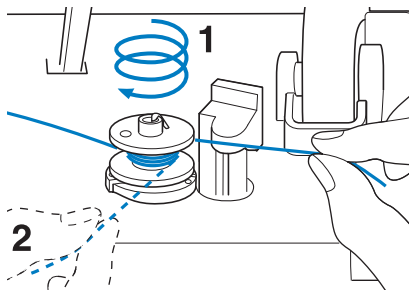

- 8** povucite kraj i provucite ga do automatskog sekača konca na nosaču špulne

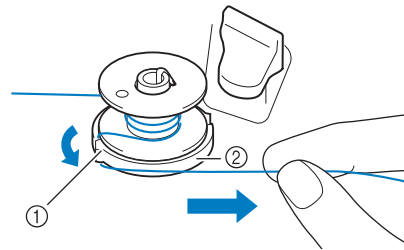

① vodilica sa sekačem

② ležište

- 9** povucite u levo motač špulne, da se namesti u poziciju i klikne

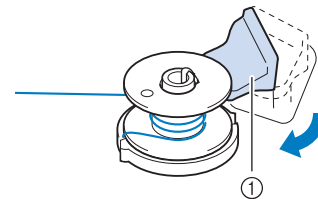

① prekidač za motanje špulne

B
1

Getting Ready

10 Pritisni **START**.

→ Namotavanje počinje automatski

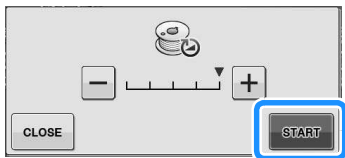

• **START** se menja u **STOP**

Pratite namotavanje i pritisnite **STOP** ako nešto nije u redu



Možete da menjate brzinu namotavanja na + ili -

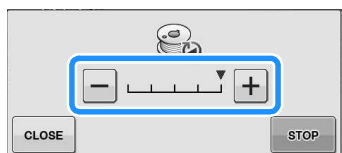

11 odsecite konac i uklonite špulnu

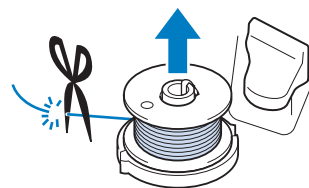

nepravilno namotana špulna može da izazove poremećaj napetosti konca i da dođe do pucanja igle ili povreda.

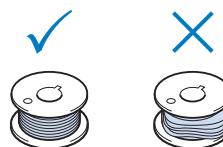

■ KORIŠĆENJE NOSAČA KONCA

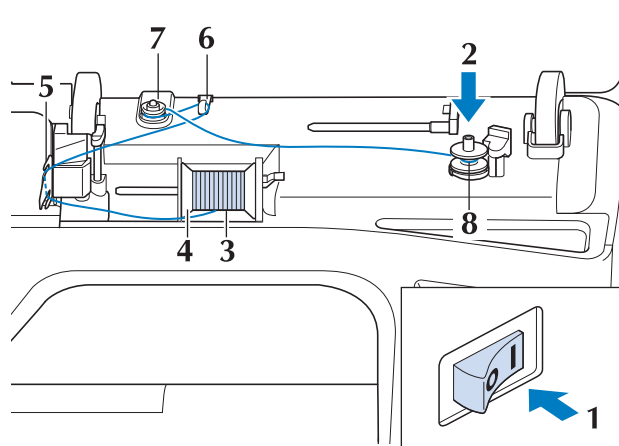

- 1 uključite mašinu i otvorite poklopac
- 2 izjednačite ispupčenje sa oprugicom

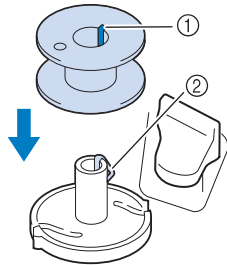

- ① ispupčenje
- ② oprugica

- 3 namestite konac kao na slici

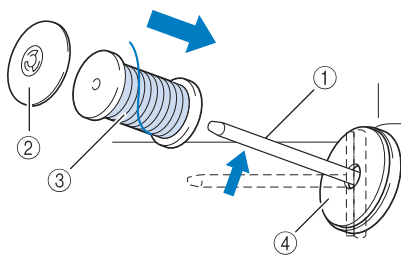

- ① nosač konca
- ② držač konca
- ③ kalem konca
- ④ postolje

- 4 podignite nosač skroz gore, a zatim vratite u početnu poziciju
- 5 dok držite konac sa obe ruke, provucite ga kroz vodiicu kao na slici

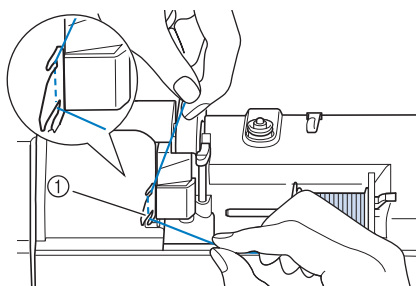

- ① vodilica

- 6 provucite konac dalje po uputstvima sa slike

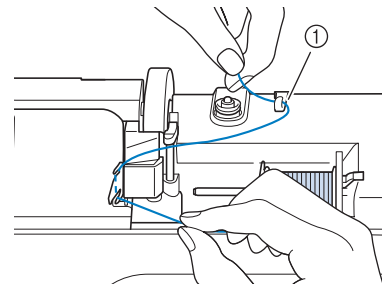

- ① vodilica

- 7 provucite konac kroz disk za tenziju

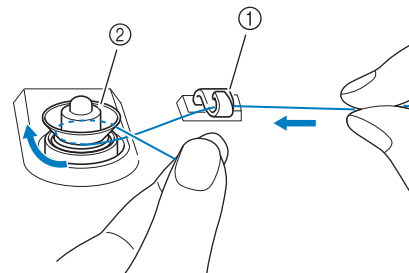

- ① vodilica
- ② disk za tenziju

- 8 pratite korake od 7 do 11 na 33. strani

■ RASPETLJAVANJE KONCA

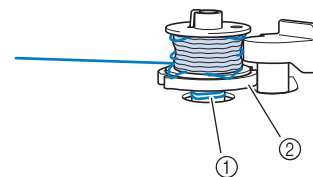

- ① konac
- ② ležište

1 ako konac počne da se mrsi, pritisnite stop

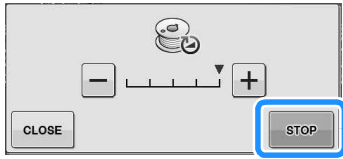

2 odsecite konac

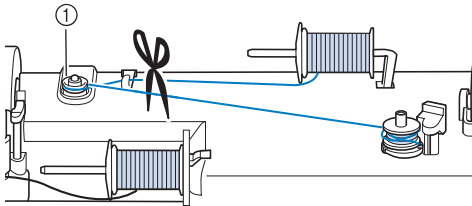

① disk za tenziju

3 gurnite špulnu u desno i podignite je za 10ak cm.

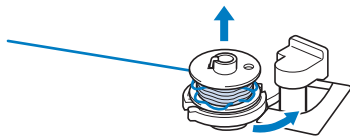

4 odsecite konac blizu špulne i držite ga levom rukom. lagano odmotavajte kao na slici

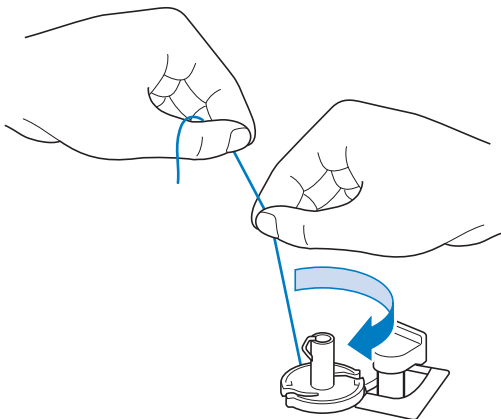

5 namotajte špulnu ponovo

POSTAVLJANJE ŠPULNE



UPOZORENJE

- Namotajte špulnu pravilno

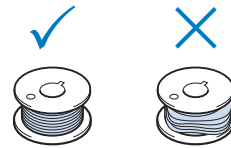

- koristite samo odgovarajuće špulne

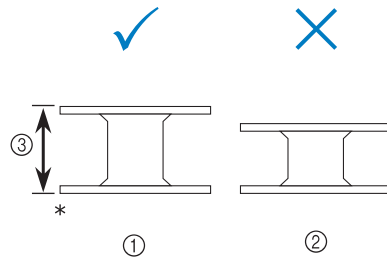

1 .

obavezno zaključajte mašinu na ovaj taster da ne bi došlo do povreda

2 otvorite poklopac grajfera na ručicu

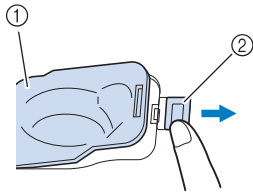

① poklopac grajfera
② ručica

3 sklonite poklopac

4 ubacite špulnu, tako da vam je konac u levoj ruci, kao na slici

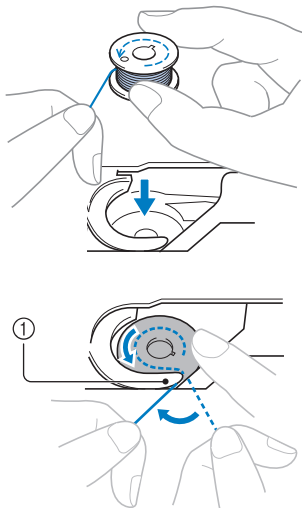

① Tab



 provucite konac kao na vodilici ispod

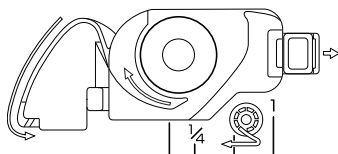

5 lagano pridržavajte konac i provlačite od 1 do 3

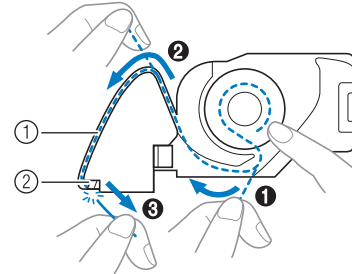

vodite računa da konac pravilno prođe kroz sve žlebove

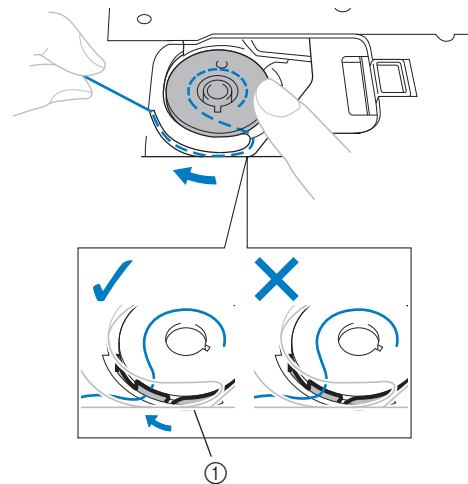

① ravna oprugica

6 vratite poklopac grajfera

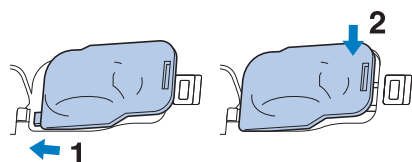

B
1

Getting Ready

GORNJI KONAC

GORNJI KONAC



pritisnite tastere gore za objašnjenje



automatski uvlačač možete upotrebiti samo za standardne debljine konca i igle

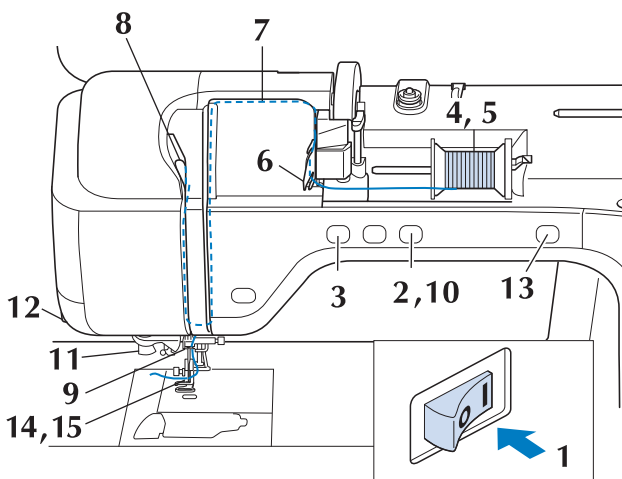

1 uključite mašinu

2 podignite stopicu

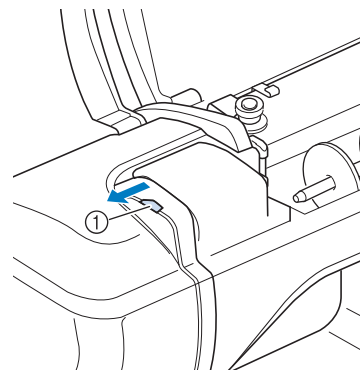
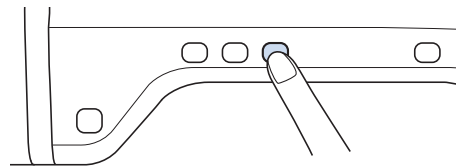

① poklopac

3 podignite iglu

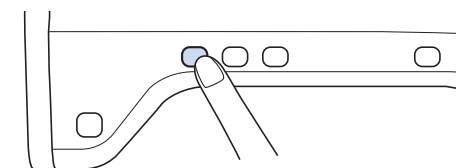

- 4** podignite nosač kalema konca

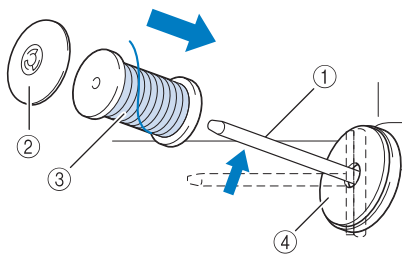

- ① nosač
- ② držač
- ③ konac
- ④ stalak

- 5** nameštite konac i držač i onda vratite nosač u početnu poziciju



- za finije kalem konca, koristite manji držač

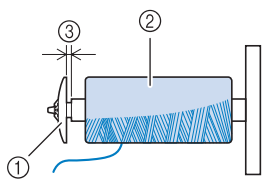

- ① manji držač
- ② kalem konca
- ③ razmak

- za specijalne kalemove, koristite specijalni držač ukoliko je to potrebno

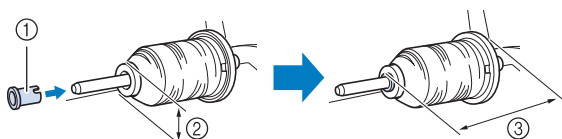

- ① specijalni držač
- ② 12 mm (1/2 inch)
- ③ 75 mm (3 inches)

- 6** Držite konac sa obe ruke i provucite kroz vodilicu

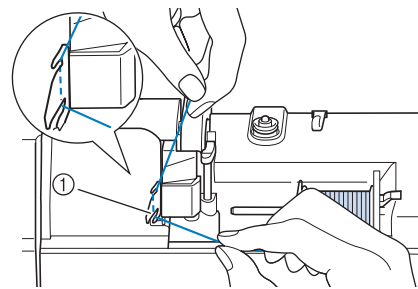

- ① vodilica

- 7** držite konac desnom rukom, a levom provlačite po navođenjima

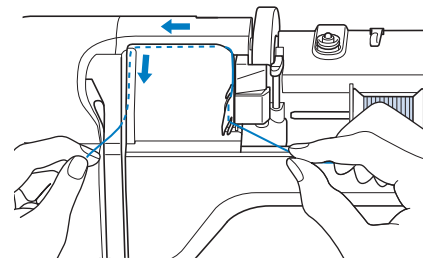

- 8** provucite konac dole, zatim gore, onda zakačite na zamajac i opet dole, kao što je na slici

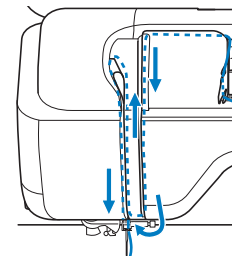

- proverite da li je konac zakačen za kukicu

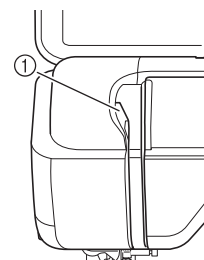

- ① kukica

- 9** zakačite konac na držač na korenu igle

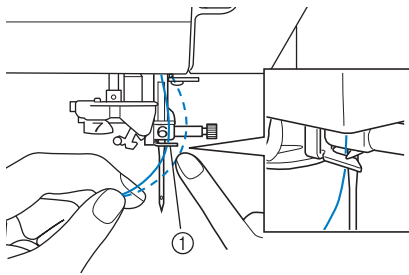

① držač

- 10** spustite stopicu

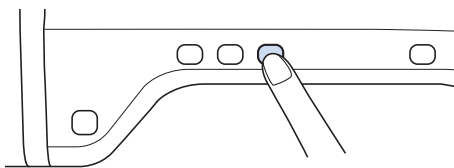

- 11** provucite konac kroz polje koje je označeno brojem 7

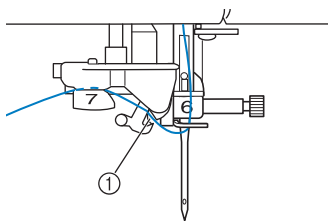

① ispupčenje

- 12** ostatak konca odsecite na sekaču, kao na slici

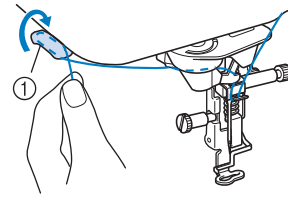

① sekač konca



ako koristite konac koji brzo klizi, ostavite malo duži kraj konca. kada isečete na sekaču, povucite još oko 80mm ostatka

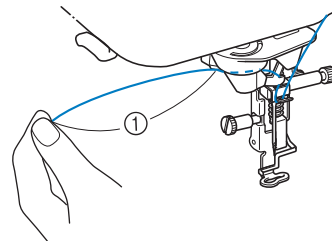

① 80 mm

- 13** pritisnite dugme za automatsko uvlačenje konca

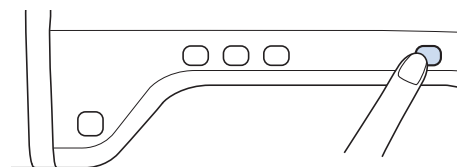

→ konac će proći kroz igleno uho

- 14 pažljivo izvucite končić koji je prošao kroz igleno uho

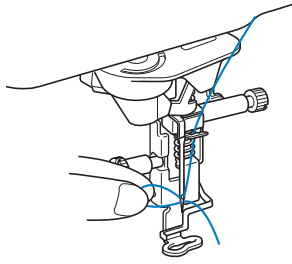

- 15 povucite oko 5cm ostatka konca

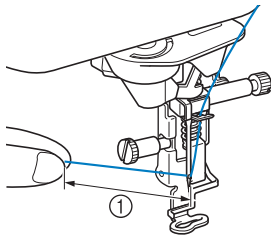

① oko 5cm

☀ specijalne igle i konci koji ne podržavaju automatsko uvlačenje, neophodno je provući ručno, od napred ka pozadi

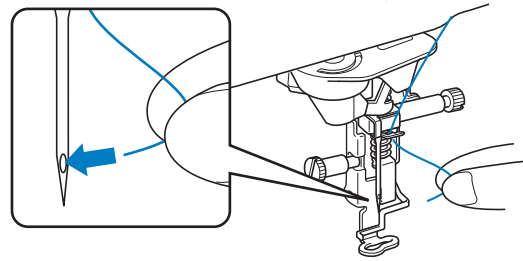

KORIŠĆENJE KONCA KOJI BRZO KLIZI

■ KORIŠĆENJE MREŽICE

Kod najlon, metalik ili drugih konaca koji brzo klize, trebalo bi koristiti mrežicu

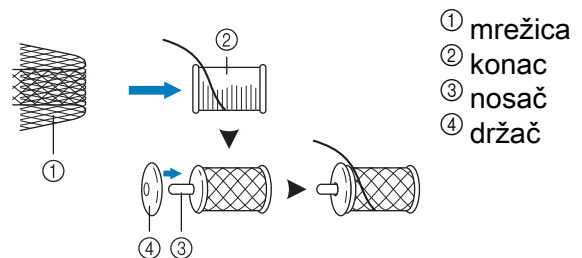

ZAMENA STOPICE ZA VEZ

NAPOMENA

Uvek zaključajte mašinu pre zamene stopice na sledeći taster:



SKLANJANJE STOPICE ZA VEZ

1 podignite iglu

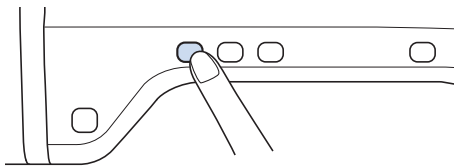

2  zaključajte mašinu

3 podignite stopicu

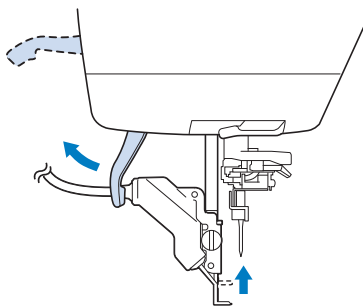

4 uključite konektor stopice u ulaz na zadnjem delu mašine

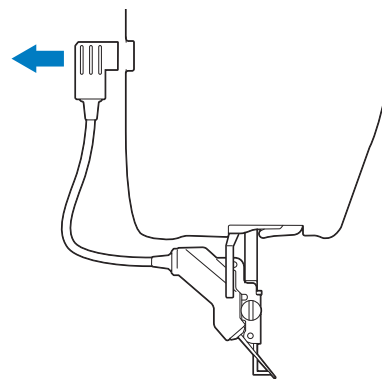

5 šrafciгерom opustite stopicu i uklonite je

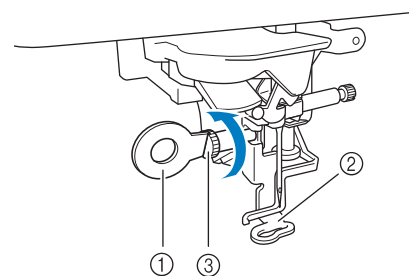

- ① šrafciгер
- ② stopica
- ③ šraf

NAMEŠTANJE STOPICE



- Pravilno pratite sve korake iz uputstva. Pogrešna primena može dovesti do povreda, loma igle i kvarova.

- 1 pozicionirajte stopicu na nosač, tako da šraf lepo ulazi u udubljenje na nosaču

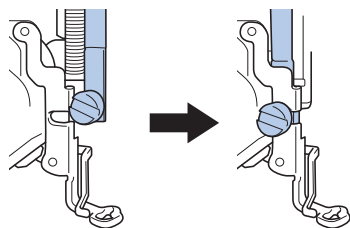

- 2 pridržavajte stopicu i zategnite šrafčiger

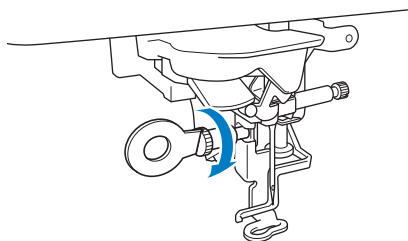

- 3 postavite konektor u ulaz pozadi

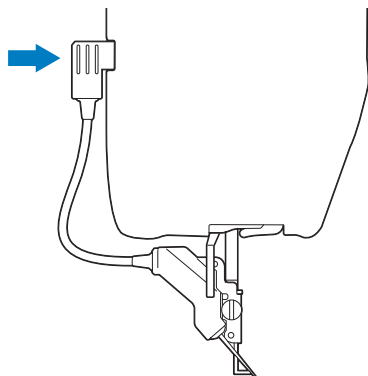

- 4  otključajte mašinu i operacije će ponovo biti dostupne

■ PROVERA UBADANJA IGLE

- 1  Pritisnite ovaj taster

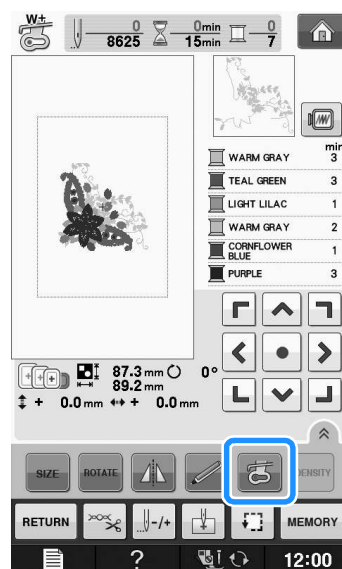

■ PODEŠAVANJA
LED
POKAZIVAČA

- 1  pritisnite taster da se pojave podešavanja
- 2 zatim strana 7

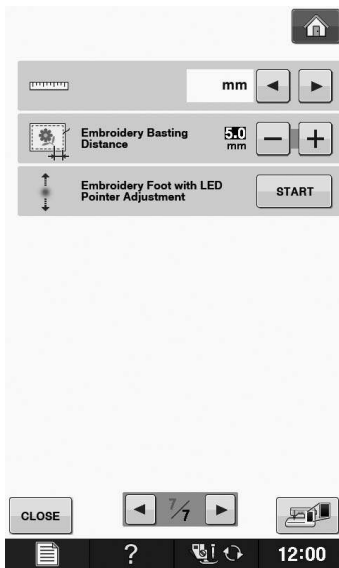

- 3  pritisnite start taster

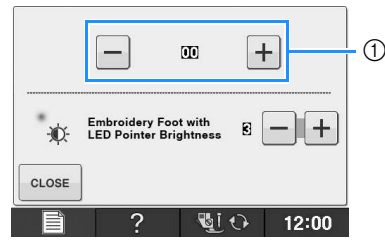



- 1  podešavanja pokazivača

- 4 koristite plus i minus za podešavanje pokazivača on pokazuje realnu poziciju uboda igle
- 5  pritisnite dva puta za vraćanje na prvu stranu

■ PODEŠAVANJE SVETLOSTI

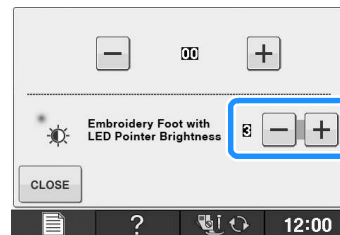
- 1 pratite korake od 1 do 4 za podešavanje pokazivača
- 2 koristite + ili - za podešavanje svetlosti



- 3  pritisnite dva puta za povratak na početnu stranu

ZAMENA IGLE

! NAPOMENA

Zaključajte mašinu pre zamene igle



proverite da li je igla ispravna

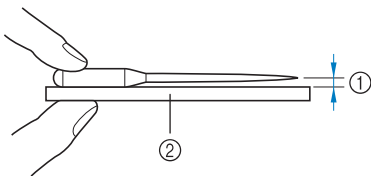

- ① paralelni prostor
- ② ravna površina

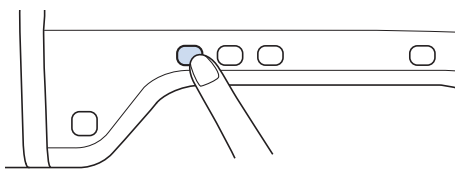
1 podignite iglu**2**

zaključajte mašinu

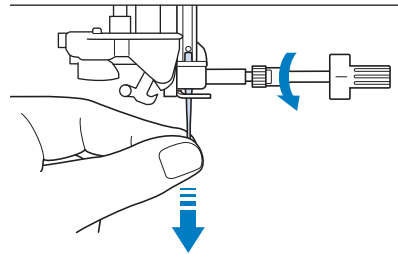
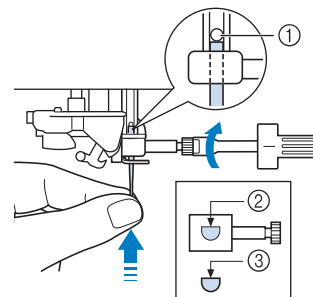
3 šrafciherom opustite nosač igle i sklonite je**4** ravna strana igle ide pozadi. pogurajte je na gore do kraja. zatim pritegnite šrafciherom

- ① kraj dokle može da uđe igla
- ② rupica za iglu
- ③ ravna strana

5

otključajte mašinu ponovo i pokrenite funkcije

B
1

Getting Ready

O IGLAMA

Vodite računa da uvek izaberete pravilne i odgovarajuće igle

PRE VEZA

VEZ KORAK PO KORAK

pratite uputstva dole

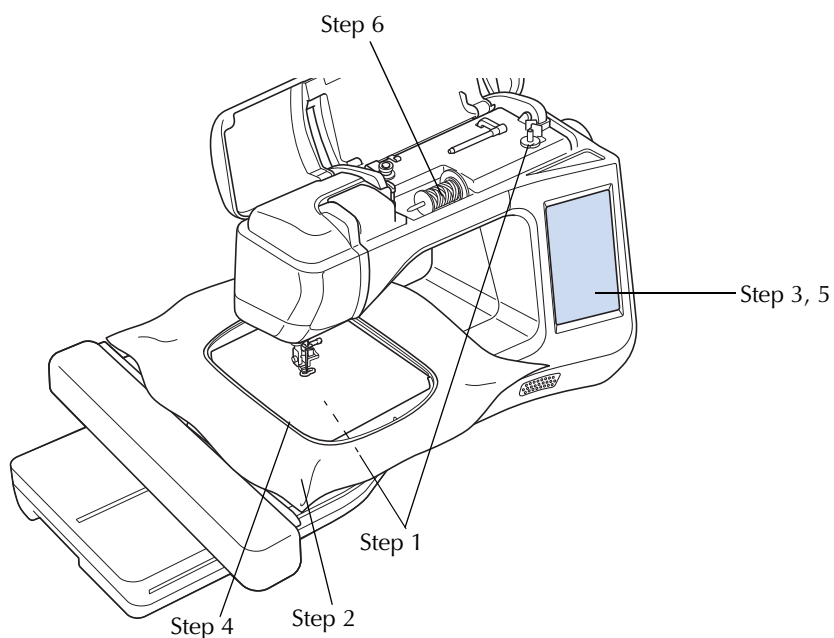

1	priprema špulne	namotajte špulnu i namestite je po uputstvima	B-31
2	priprema materijla	postavite stabilizator i prikacite materijal na ram	E-11 to E-17
3	odabir dizajna	izaberite dizajn	E-3
4	prikačite ram za vez	prikačite ram za veznu jedinicu	E-17
5	provera projekta	proverite podešavanja	E-19
6	podešavanja konca	podesite konac u skladu sa vezom	E-21

O VEZNOJ JEDINICI

■ sklanjanje vezne jedinice

1 Pritisnite ovaj  ili ovaj taster



a zatim



2 isključite mašinu

3 pritisnite dugme i oslobodite veznu jedinicu

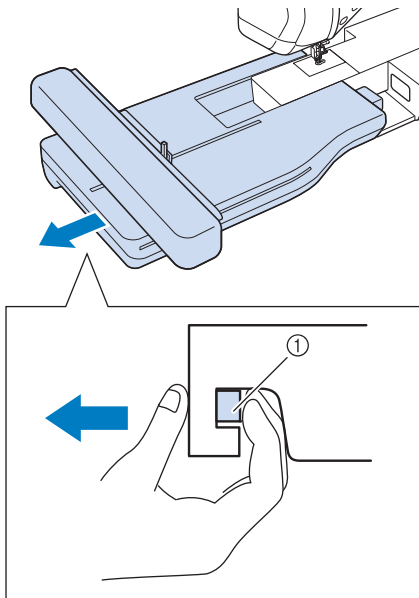

① dugme za oslobađanje

• vodite računa kako nosite veznu jedinicu

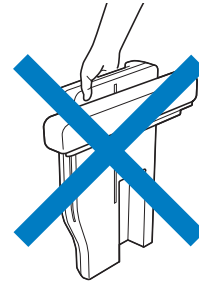

■ POSTAVLJANJE VEZNE JEDINICE

pratite uputstva dole

1 isključite mašinu

B
1

Getting Ready

2 postavite veznu jedinicu na mašinu

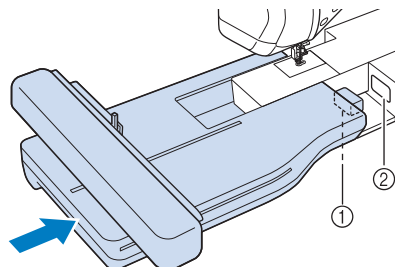

- ① konektor vezne jedinice
- ② ulaz za konekciju na mašini

3 uključite mašinu

4  pritisnite ok



vezna jedinica se pomera u inicijalnu poziciju

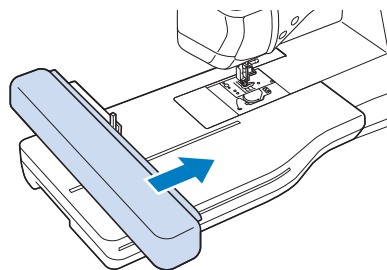

UPOTREBA FUNKCIJA
KOD KORIŠĆENJA PRIBORA

KORIŠĆENJE USBa ILI KARTICE

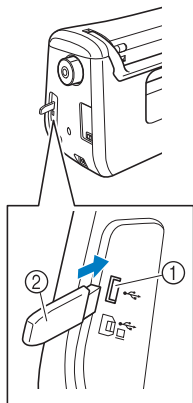

- ① ulaz za USB
- ② USB

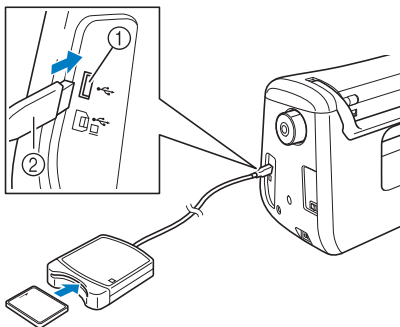

- ① usb za miša
- ② čitač kartice

PRIKLJUČIVANJE MAŠINE ZA KOMPJUTER

uz pomoć USB kabla, možete povezati mašinu i kompjuter

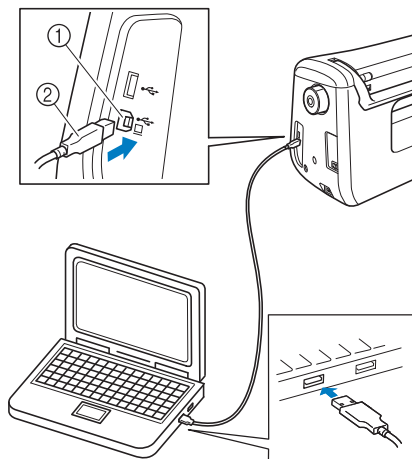

- ① ulaz
- ② kabl

UPOTREBA USB MIŠA

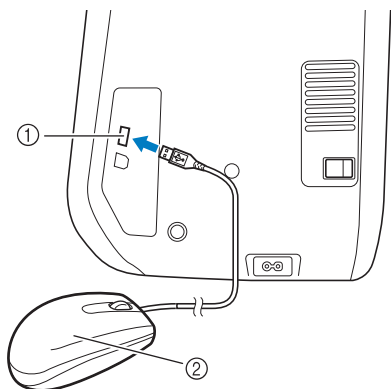

- ① ulaz
- ② miš

■ kada je miš povezan, pomerajte ga tamo gde želite da kliknete. pokazivač će pritiskom na određenu funkciju pokrenuti istu.

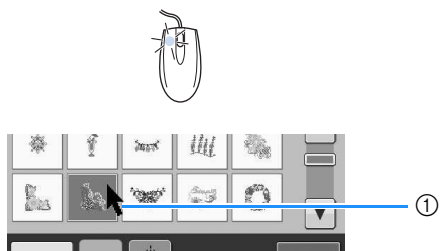

- ① pokazivač

■ ZAMENA STRANA

listajte stranice, kliktanjem na strelice

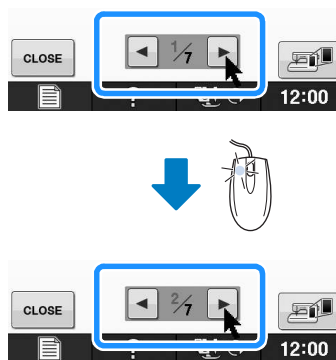

B *Basic operations*

POGLAVLJE

2

SENZORNE FUNKCIJE

POVEZIVANJE OLOVKE NA SENZOR.....	53
Korišćenje držača olovke	53
KORIŠĆENJE OLOVKE.....	55
Korišćenje olovke	55
Važne informacije.....	55
Kalibriranje olovke.....	56
KORIŠĆENJE SENZORSKIH FUNKCIJA	
“EMBROIDERY”/“EMBROIDERY EDIT” MODU	58
PRECIZIRANJE POZICIJE VEZA.....	58
■ Selektovanje pozicije veza u odnosu na ivice dizajna	59
■ Selektovanje pozicije veza u odnosu na centar dizajna.....	60

POVEZIVANJE OLOVKE

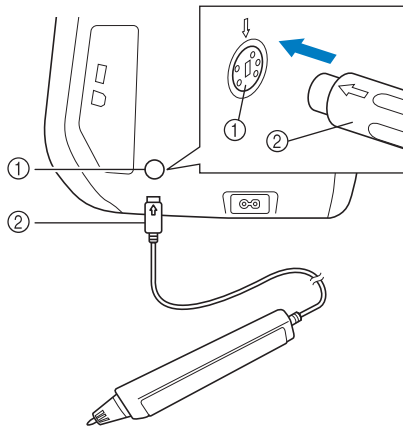

- ① utikač olovke
- ② ulaz za olovku

Korišćenje držača olovke

kada povežete mašinu i olovku, prikačite i dodatak koji će poslužiti kao držač olovke



držač

- 1 iskoristite kraj paralice ili četkice, da otvorite rupicu na mašini, kao na slici

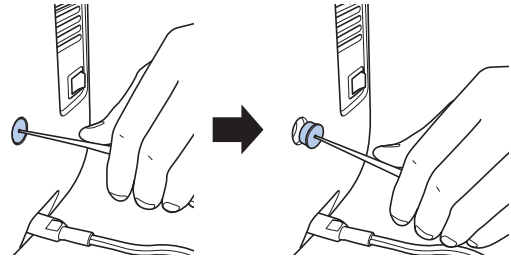

- 2 čvrsto ubacite držač u rupicu koju ste otvorili

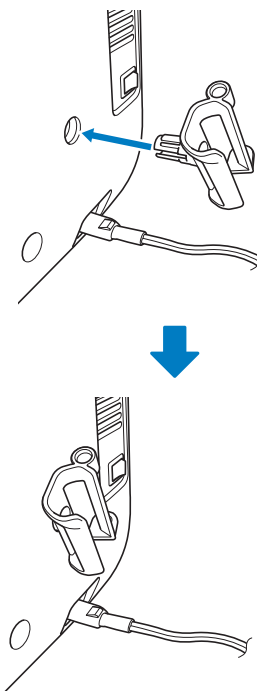

3 namestite olovku u držač

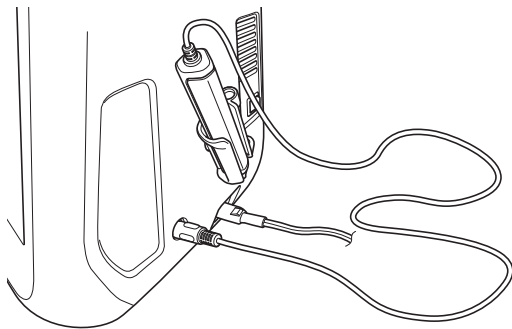

KORIŠĆENJE OLOVKE

B
2

Sensor Functions (For models equipped with the sensor function)

KORIŠĆENJE OLOVKE

olovku koristite nežno i pažljivo

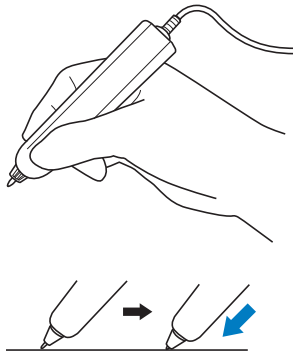

- 1) kratkim klikom na određenu ikonicu, dobijate selektovanje iste
- 2) ako držite par sekundi, pokrećete željenu funkciju

Važne informacije

senzorna olovka emituje signal koji šalje vašoj mašini

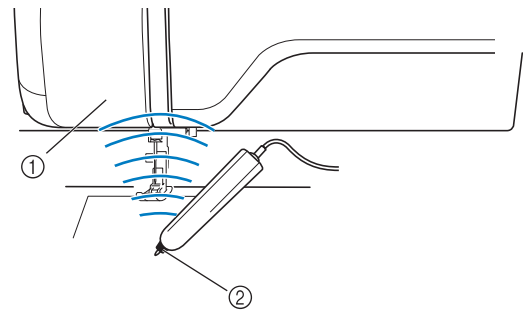

- ① primanje signala
- ② vrh olovke

Kalibriranje olovke

kada prvi put uključite olovku, budite sigurni da je držite pravilno i udobno.
kalibriranje olovke će biti od pomoći mašini pri prepoznavanju daljih funkcija

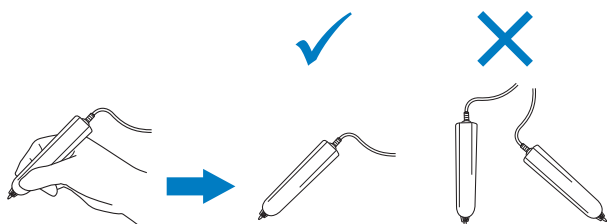

- 1  - pritisnite
- 2 strana 3

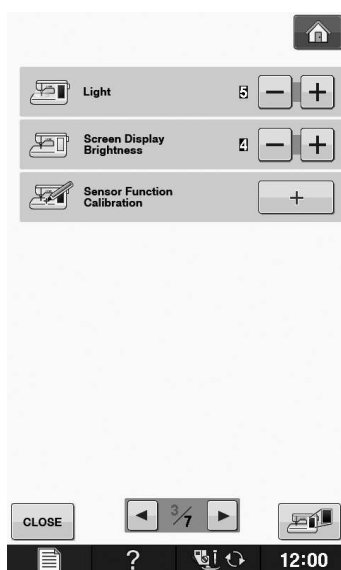

- 3 Connect the sensor pen to the machine and then press .

→ The Sensor Function Calibration screen appears.

- 4 dodirnite zelenu tačku na ubodnoj ploči koristeći olovku

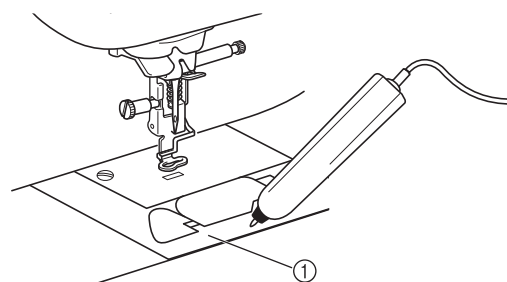
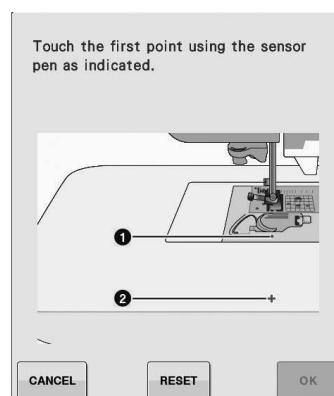

- ① poklopac ubodne ploče

- 5 dodirnite drugu tačku u centar

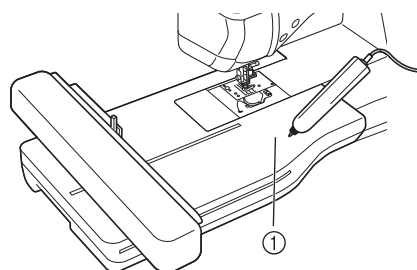
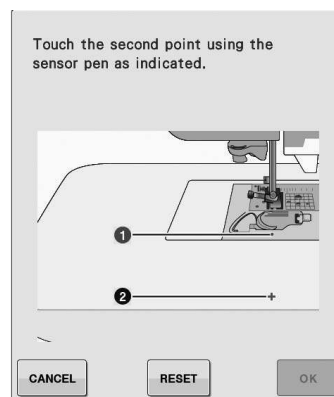

- ① vezna jedinica

6

pritisnite ok da završite kalibriranje

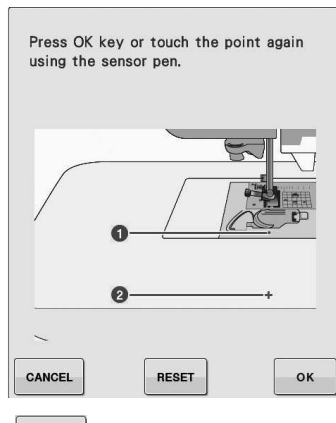

pritisnite cancel da se vratite na
početnu stranu
pritisnite reset da opet podesite
kalibriranje

**B
2**



Sensor Functions (For models equipped with the sensor function)

KORIŠĆENJE SENZORSKIH FUNKCIJA “EMBROIDERY”/“EMBROIDERY EDIT” MODU

PRECIZIRANJE POZICIJE VEZA

upotrebom senzorne olovke,
možete podešavati poziciju veza

1 uključite mašinu

2 pritisnite  (Embroidery)/
 (Embroidery Edit).

3 odaberite kategoriju za vez

4 na selekcionom ekranu, izaberite vez

5  pritisnite

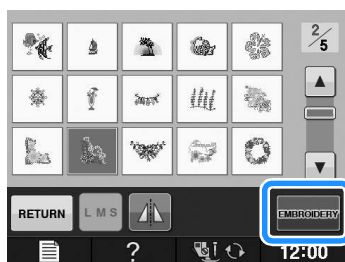

6 tkaninu namestite na ram i zakačite
ram za mašinu

7  pritisnite

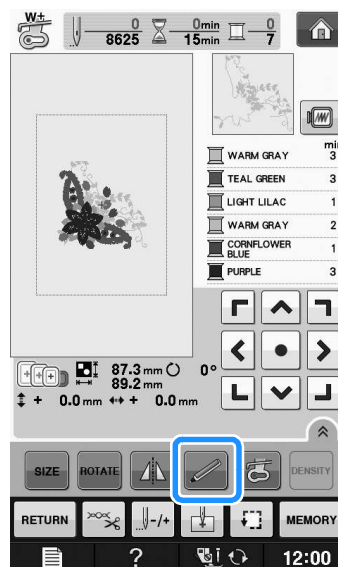

odaberite željenu oblast i pritisnite ok

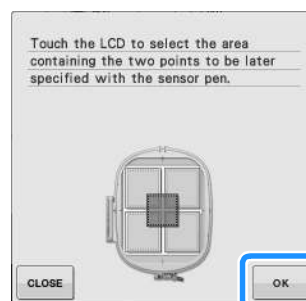

8

OK pritisnite

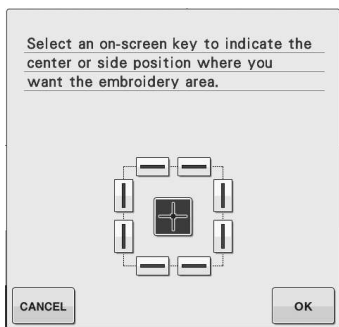
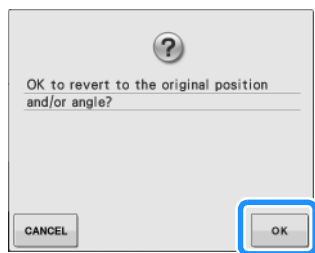

9

izaberite metod za pozicioniranje veza

■ Selektovanje pozicije veza u odnosu na ivice dizajna

1

od  na ekranu, kliknite na ivicu

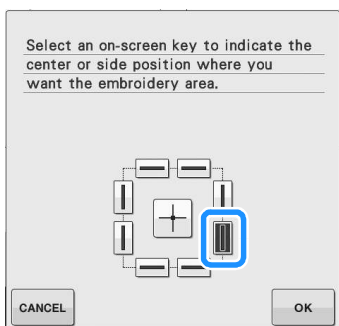

2

zanim OK

3

senzornom olovkom kliknite na poziciju 1

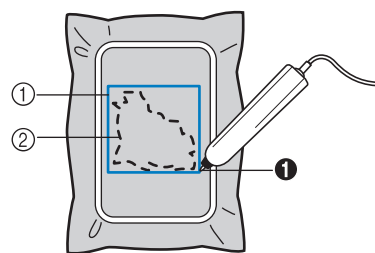
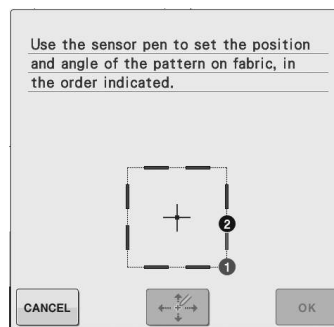

- ① kvadrat ivice veza
- ② pozicija

4

zatim kliknite na poziciju 2

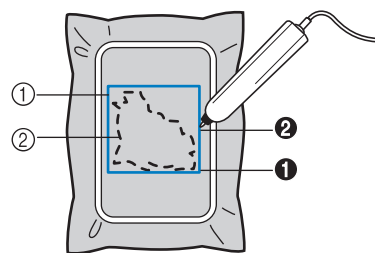
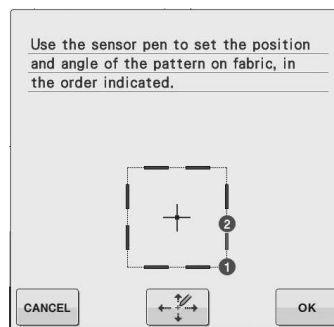

- ① kvadrat ivice veza
- ② pozicija

5

 pritisnite da podesite poziciju

6

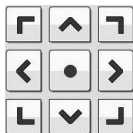

pritisnite da pomerite pokazivač na tkanini za podešavanje prve pozicije

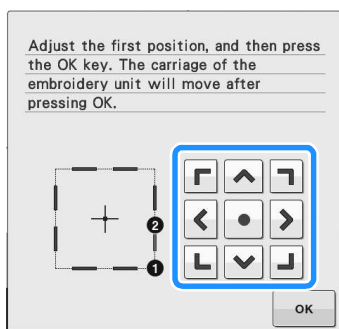

7 zatim



8

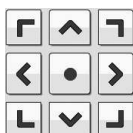

pritisnite da pomerite pokazivač na tkanini za podešavanje druge pozicije

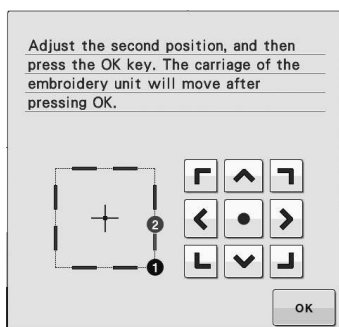

9 zatim



10 pregled na ekranu je ažuriran pozicijom

11 pritisnite start da vezete

■ Selektovanje pozicije veza u odnosu na centar dizajna

1

pritisnite na sledećem ekranu

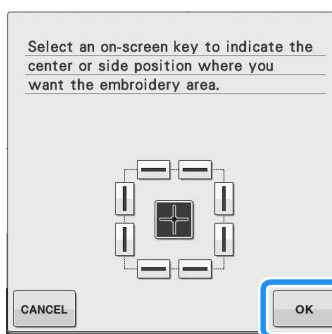

2 olovkom dodirnite dve tačke na materijalu u odnosu na brojeve u centru

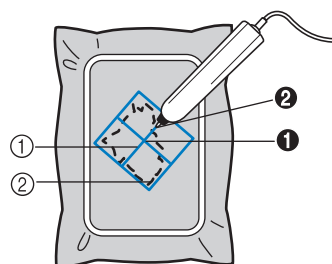
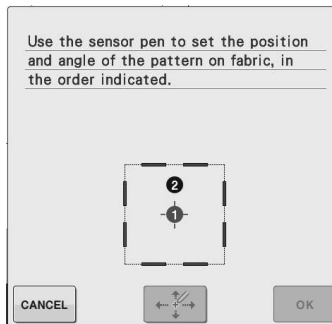

- ① centralna linija
- ② pozicija

3

pritisnite za podešavanje pozicije

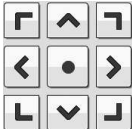

- 4  pritisnite da pomerite pokazivač u prvu poziciju

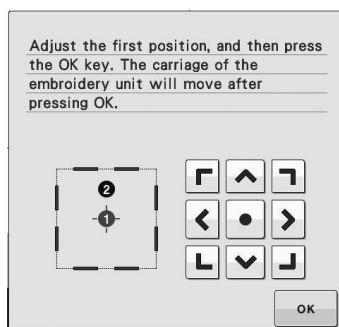

- 5 zatim 

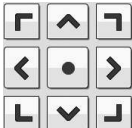
- 6  pritisnite da pomerite pokazivač za podešavanje druge pozicije

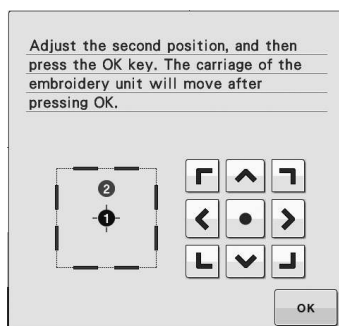

- 7 zatim  1

- 8 pregled na ekranu je ažuriran u skladu sa vašim podešavanjima

- 9 pritisnite start za vez



poglavlje 1- VEZ **E-2**

poglavlje 2-PODEŠAVANJA VEZA..... **E-56**

POGLAVLJE 1

VEZ

Odabir dizajna	3
■ Informacije o autorskim pravima	3
Odabir veznog dizajna	4
Odabir karaktera dizajna.....	5
Odabir rama.....	7
Odabir sa memorijske kartice.....	7
■ O karticii USBu.....	7
■ O karticii za vez	7
odabir bodova sa USBa	8
Pregled ekrana za vez	9
■ Funkcije.....	10
Priprema materijala	11
Pričvršćivanje stabilizatora	11
Nameštanje platna na ram	13
■ Tipovi ramova	13
■ Ubacivanje.....	14
■ Korišćenje mreže za vez	15
Vez na malim platnima	16
■ Vez na malim platnima.....	16
■ Vez na ivicama ili uglovima.....	16
■ Vez na trakama.....	16
Postavljanje rama za vez	17
■ Skidanje rama za vez.....	17
Portvrda pozicije dizajna	19
provera pozicije dizajna	19
Pregled kompletnog dizajna	20
Šivenje dizajna veza.....	21
Vezni atraktivni završeci	21
■ Poklopac za ubodnu ploču	22
Šivenje vezenog dizajna	22
Šivenje vezenog dizajna kao aplikacija	23
Podešavanja za vreme veznog procesa.....	26
Ako ponestane donji konac	26
Ako pukne konac	27
Kretanje iz početka	28
Nastaviti vez nakon isključenja.....	28
Podešavanja veza.....	30
Podešavanje napetosti	30
■ Ispravna napetost	30
■ Gornji konac je prezategnut	30
■ Gornji konac je prelabav.....	30
Podešavanja špulne	31
■ Ispravna napetost	31
■ Donji konac je prelabav	31
■ Donji konac je prezategnut	32
Automatski sekač konca.....	32
Funkcija skraćivanja	32
■ Podešavanje dužine preskočenog boda koji se ne skraćuje.....	33
Podešavanje brzine	33
Promena boje	34
Promena ekrana.....	35
Preispitivanje dizajna	36
Pomeranje dizajna.....	36
Izjednačavanje dizajna i igle	36
promena veličine	37
Rotiranje	38
Horizontalno ogledalo	39
Proširenje ekrana.....	39
Promena gustine	40
Promena boje kod slova	40
Vezani karakteri	41
Neprekidan, jednobojan vez	43
Memorija.....	44
Mere predostrožnosti.....	44
■ Tipovi podataka koji mogu da se koriste.....	44
■ Tipovi USBa koji mogu da se koriste	44
■ operativni sistemi koji mogu da se koriste.....	44
■ Mere predostrožnosti kod čuvanja podataka.....	44
■ Tajima (.dst) Podaci o vezu	45
Čuvanje na memoriju mašine	45
■ Ako je memorija puna.....	45
Čuvanje na USB.....	46
Čuvanje na kompjuter.....	47
Povrat podataka iz mašine u kompjuter	48
povlačenje sa USBa	49
Povlačenje sa kompjutera	50
Aplikacije.....	51
Korišćenje rama za izradu Appliqué (1).....	51
Korišćenje rama za izradu Appliqué (2).....	52
Šivenje odvojenih dizajna.....	53

ODABIR DIZAJNA

■ Informacije o autorskim pravima

Dizajn koji je ponuđen u mašini je namenjen samo za privatnu upotrebu.

pritisnite , zatim  t da se prikaže ekran koji je dole postoji 6 kategorija dizajna

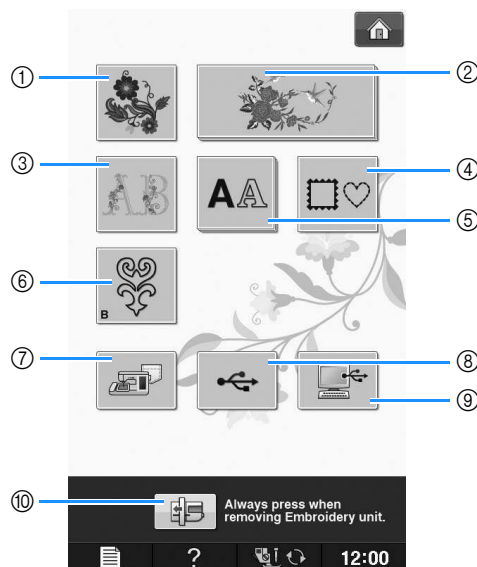

- ① vezni dizajni
- ② ekskluzivni brother dizajni
- ③ cvetna slova
- ④ okviri, uramljivanje
- ⑤ karakteri
- ⑥ rad sa špulnom
- ⑦ dizajn koji ste sačuvali na mašini
- ⑧ dizajn koji ste sačuvali na USBu
- ⑨ dizajn koji ste sačuvali na kompjuteru
- ⑩ pritisnite da pozicionirate veznu jedinicu

ODABIR DIZAJNA

- 1 klikom odaberite željenu kategoriju



- 2 kliknite na željeni dizajn

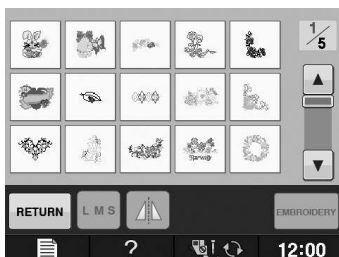

- 3 pritisnite ukoliko želite sliku kao u ogledalu

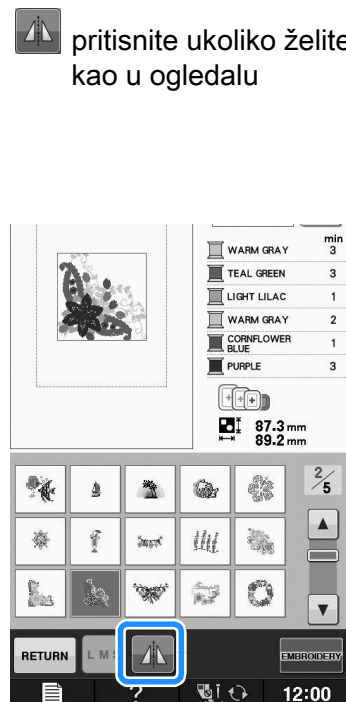

- 4 pritisnite

- 5 nastavite sa pregledom ekrana za vez

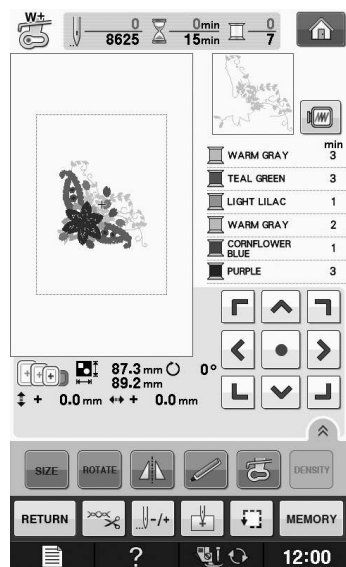

ODABIR KARAKTERA

Primer: "We Fly".

1  . pritisnite

2 izaberite font

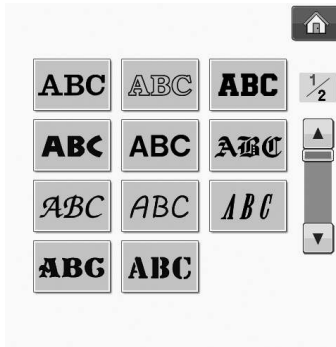

3 pritisnite da promenite selekcioni ekran



4 pritisnite  i zatim unesite "W".



5 pritisnite  i unesite "e".

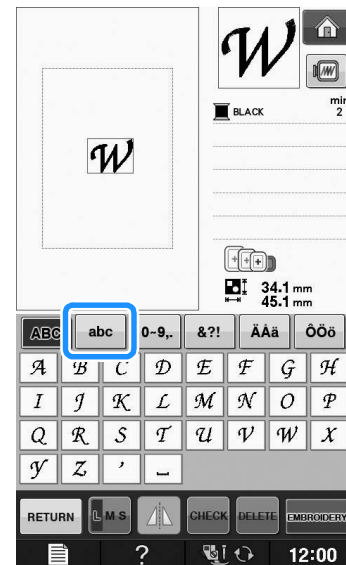

6 pritisnite  za razmak



7 pritisnite **ABC** i unesite "F".

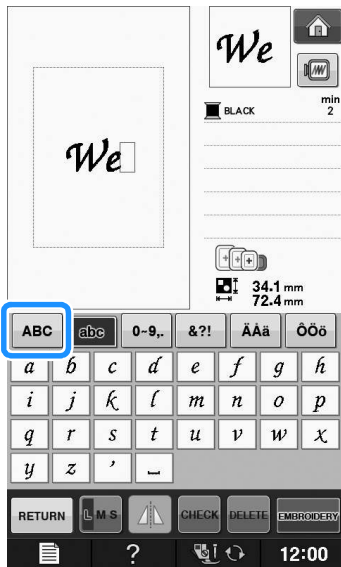

8 pritisnite **abc** i unesite "ly".



9 pritisnite **EMBROIDERY**.



10 nastavite sa pregledom ekrana za vez

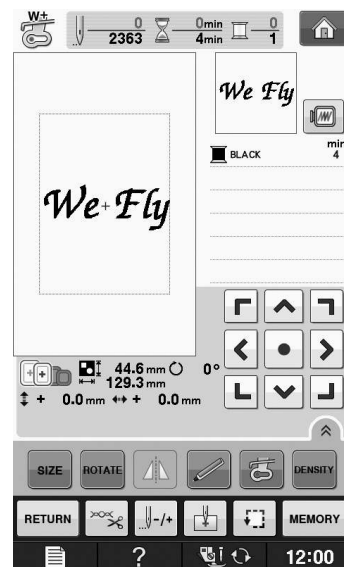

URAMLJIVANJE; OKVIRI

1 pritisnite .

2 izaberite željeni oblik rama

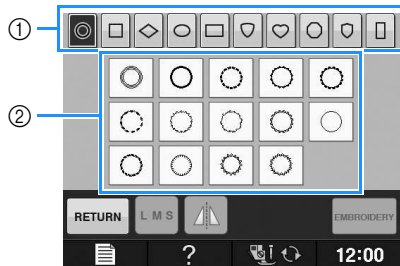

① oblik

② dizajn

3 pritisnite na ram koji želite da vezete

4 pritisnite .

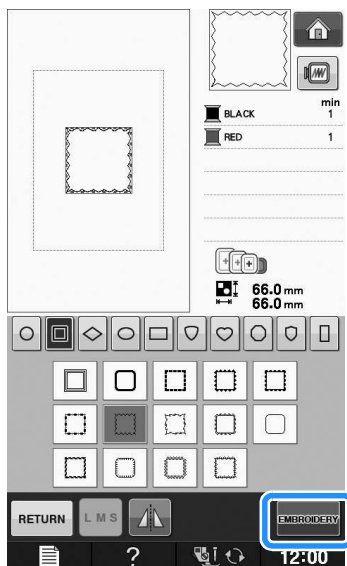

5 nastavite sa pregledom na ekran za vez

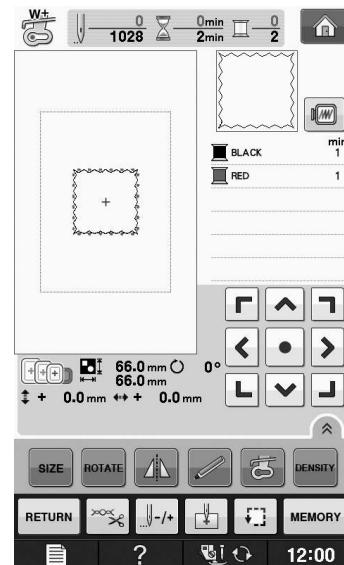

ODABIR DIZAJNA SA KARTICE

■ O memorijskoj kartici

koristite samo memorijske kartice koje su namenjene mašini

- 1 ubacite čitač za karticu u ulaz za USB

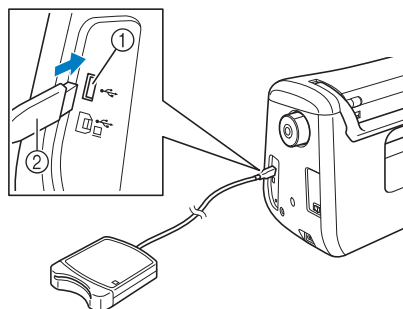

- ① ulaz
② kartica

- 2 stavite karticu u čitač

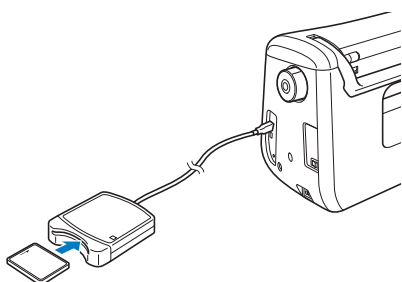

- 3 pritisnite ikonicu za USB

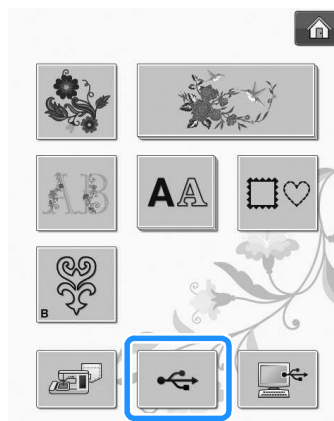

- 4 pratite korake na strani E4, da izaberete dizajn

ODABIR DIZAJNA SA USBa

Procedura je ista kao za karticu

PREGLED EKRANA ZA VEZ

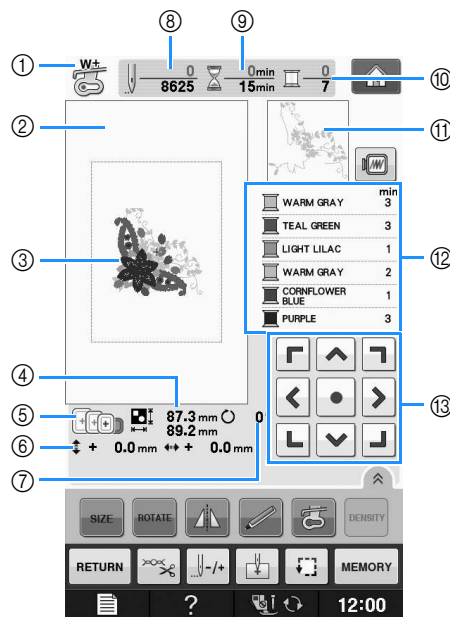

- ① prikazuje stopicu
- ② prikazuje granice veza
- ③ prikazuje prethodno selektovan dizajn
- ④ prikazuje veličinu dizajna
- ⑤ prikazuje ram
- ⑥ prikazuje udaljenost od centra
- ⑦ prikazuje ugao rotacije
- ⑧ prikazuje broj bodova
- ⑨ prikazuje vreme potrebno za vez
- ⑩ prikazuje broj boja
- ⑪ prikazuje deo koji će biti prvi pri vezu
- ⑫ prikazuje vreme veza za svakuboju pojedinačno

■ funkcioni tasteri

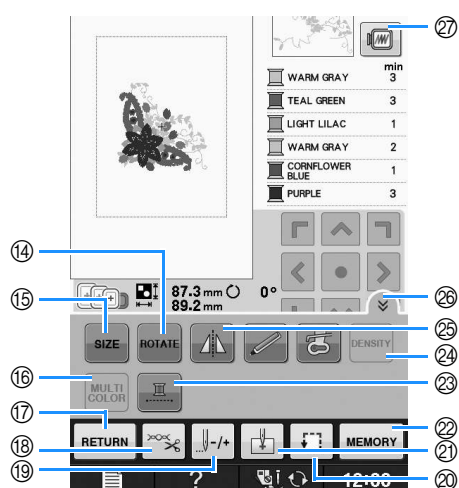

13		strelice za pomeranje dizajna
14		Rotacija
15		promena veličine
16		promena boje
17		vraćanje
18		sečenje konca
19		pomeranje igle
20		provera pozicije
21		promena startne pozicije igle
22		memorija
23		vez jednom bojom
24		gustina
25		horizontalno ogledalo
26		svi tasteri
27		pregled

PRIPREMA MATERIJALA

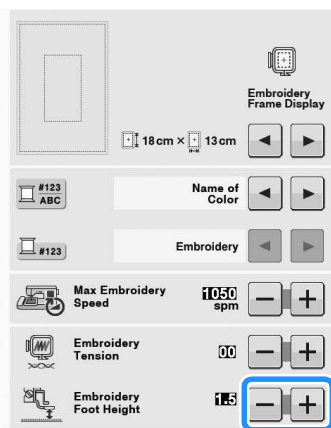
E
1

ako želite da povećate razak između stopice i ubodne ploče, stavite na veći broj od 1,5

STAVLJANJE STABILIZATORA

za najbolje rezultate veza, koristite stabilizatore.

postoji više vrsta stabilizatora i upotrebite onaj koji je u skladu sa vašim materijalom i projektom.

1 stabilizator treba da bude veći od rama

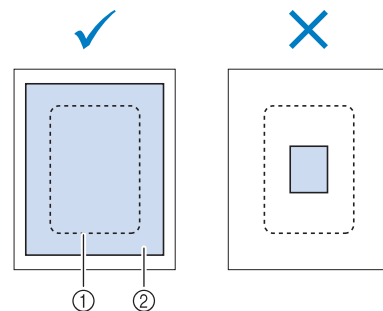

- ① veličina rama
- ② stabilizator

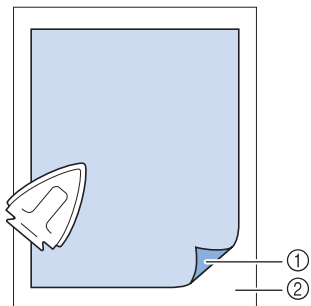

2 upeglajte stabilizator za materijal



- ① lice stabilizatora
- ② naličje tkanine

NAMEŠTANJE MATERIJALA U RAM

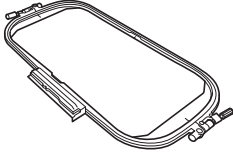
■ Tipovi ramova

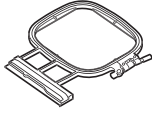
		
30 cm × 18 cm (approx. 12 inches × 7 inches)	18 cm × 13 cm (approx. 7 inches × 5 inches)	10 cm × 10 cm (approx. 4 inches × 4 inches)

izaberite ram koji odgovara vašem dizajnu i materijalu

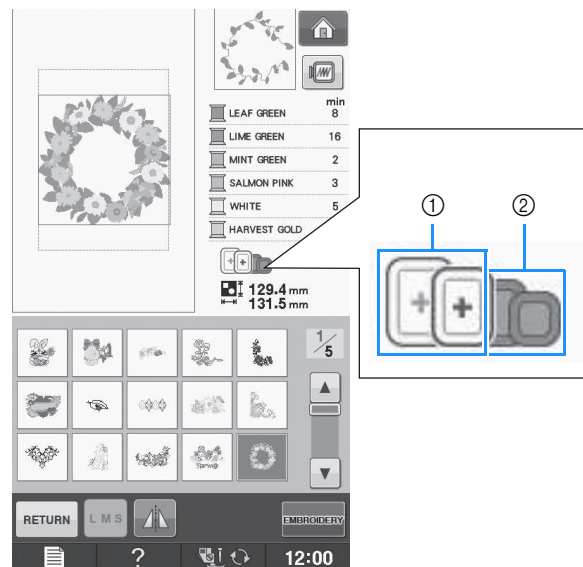

- ① osvetljeni ram- može da se koristi za odabrani dizajn
- ② zatamljeni ram- ne može da se koristi za odabrani dizajn

UBACIVANJE MATERIJALA

- 1 razdvojite unutrašnji ram od spoljašnjeg, oslobađanjem zavrtnje na šraf

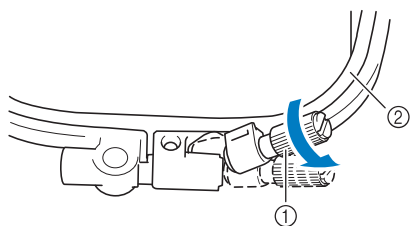

- ① šraf
② unutrašnji ram

- 2 postavite materijal licem na gore

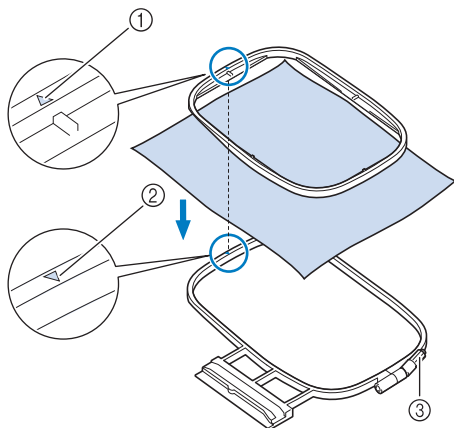

- ① unutrašnji ram
② spoljašnji ram
③ šraf

- 3 lagano pričvrstite materijal

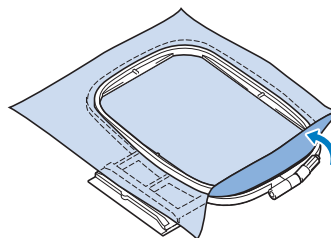

- 4 pažljivo zategnite materijal i počnite sa pričvršćivanjem na šraf

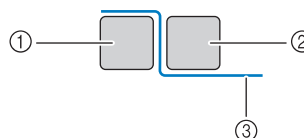
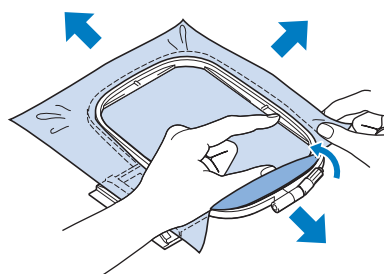

- ① spoljašnji ram
② unutrašnji ram
③ materijal

5 postavite šraf u inicijalnu poziciju

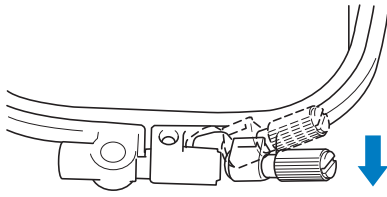

 možete da koristite i šrafčiger

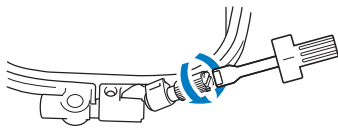

■ KORIŠĆENJE MREŽICE ZA VEZ

1 obeležite oblast koju želite da vezete

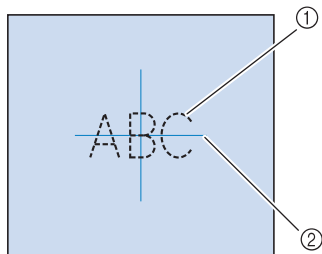

① dizajn
② oznaka

2 postavite mrežicu na unutrašnji ram

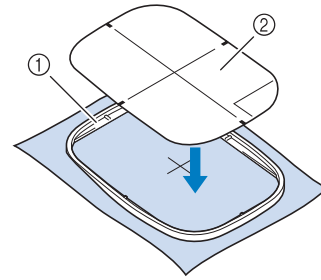

① unutrašnji ram
② vodilica na mrežici

3 lagano zategnite materijal, da nema izgužvanih i neravnih delova

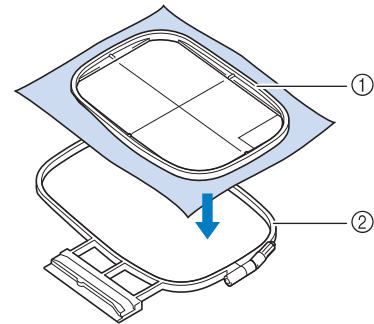

① unutrašnji ram
② spoljašnji ram

4 skinite mrežicu

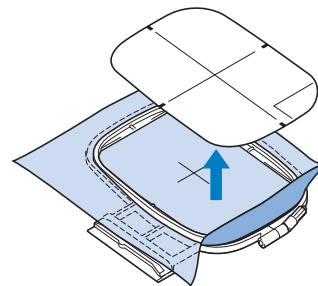

VEZ NA MALIM MATERIJALIMA ILI PO IVICAMA

koristite stabilizator za bolje rezultate

■ vez na malim aterijalima

koristite lepak u spreju i privremeno prilepите
manji materijal na veće platno i stabilizator

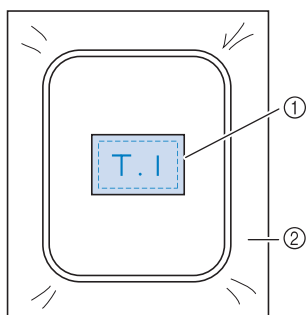

- ① materijal
- ② stabilizator

■ vez po ivicama

upotrebite lepak u spreju kao podršku za veću
površinu ili ufircajte stabilizator za krajeve

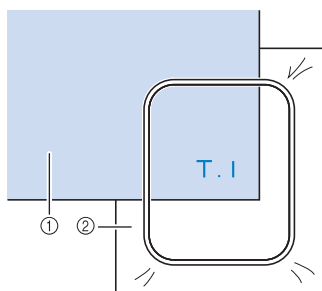

- ① materijal
- ② stabilizator

■ VEZ NA TRAKAMA pričvrstite lepkom u spreju

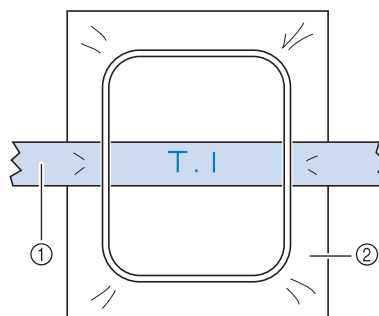

- ① traka
- ② stabilizator

STAVLJANJE RAMA ZA VEZ

E
1

Embroidery

- 1 podignite stopicu
- 2 izjednačite ram sa nosačem rama

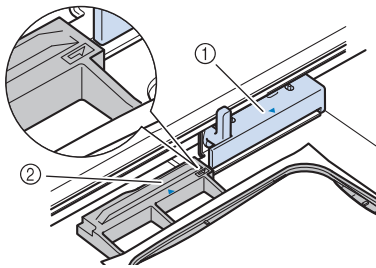

- ① nosač rama
- ② vodilica

- 3 pažljivo gurnite, da ram sklizne u nosač

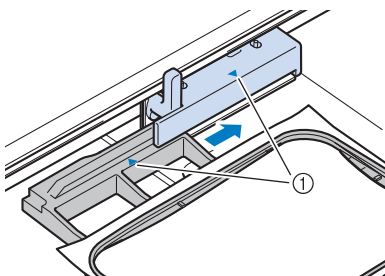

- ① pratite znak strelice

- 4 spustite polugicu za zaključavanje i osigurajte ram

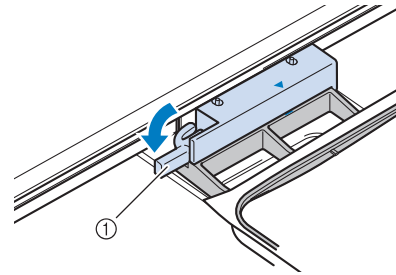

- ① polugica za zaključavanje

■ SKLANJANJE RAMA

- 1 podignite polugicu za zaključavanje

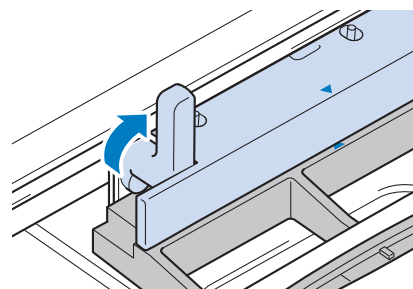

2 povucite ram ka vama

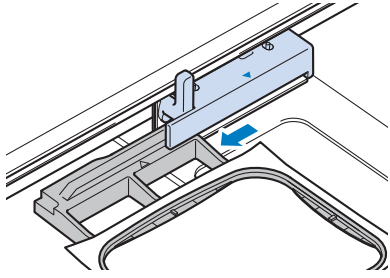

POTVRDA POZICIJE DIZAJNA

E
1

Embroidery

PROVERA POZICIJE DIZAJNA

ram se pomera i pokazuje gde će biti vaš vez

1

 .pritisnite

2

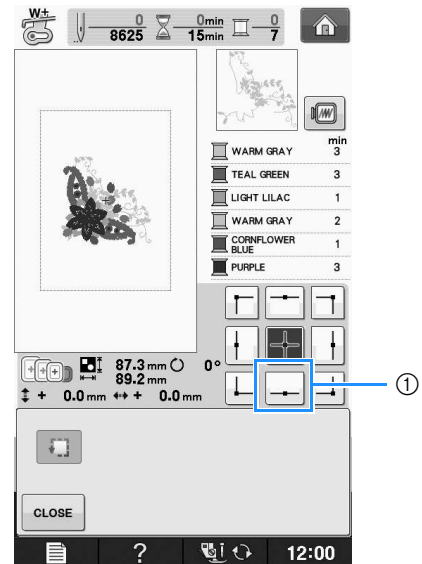
 , označite poziciju koju želite da proverite

① izabrana pozicija

 Memo

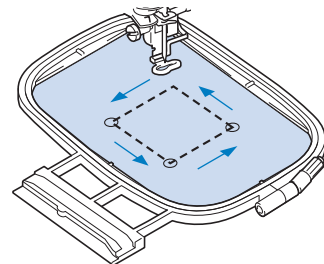
 .pritisnite da biste imali pregled celog projekta

3

 .pritisnite

PREGLED CELOG DIZAJNA

1  -pritisnite

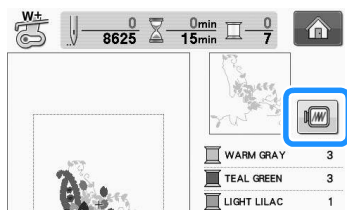

pojaviće se slika

2    

pritisnite da izaberete ram



3  pritisnite da se vratite na početni ekran

ŠIVENJE IZVEZENOG DIZAJNA

ATRAKTIVNI ZAVRŠECI

postoji nekoliko faktora koji će učiniti da vaš vez izgleda lepše i urednije.
to su gore pomenuti stabilizatori, pravilno nameštanje na ram, ali i napetost konca

napetost konca špulne možete podešavate na šrafu grajfera.

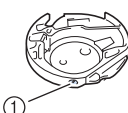
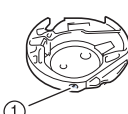
<p>grajfer</p>  <p>① šraf</p>	<p>standardni grajfer ima šraf na kome mogu da se promene podešavanja</p>
<p>grajfer za vez</p>  <p>① šraf</p>	<p>grajfer za vez ima šraf na kome mogu da se promene podešavanja</p>

■ poklopac za ubodnu ploču

u nekim slučajevima će biti potrebno da namestite poklopac na ubodnu ploču

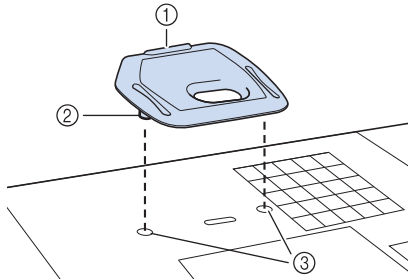

- ① ispupčenje
- ② ulaz
- ③ udubljenja

ŠIVENJE DIZAJNA

primer:

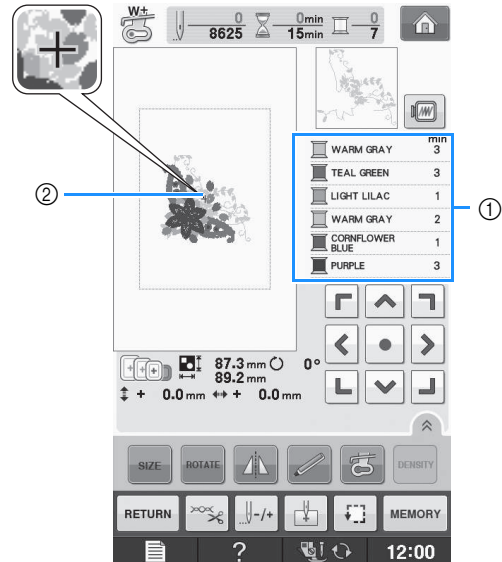

- ① boje
- ② kursor

 na + se pomera kursor i pokazuje koji deo je ušiven

- 1 uvucite prvu boju konca kojom ćete započeti vez.
provucite konac kroz stopicu za vez

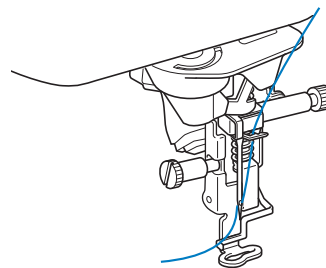

2 spustite stopicu i pritisnite start stop dugme posle 5,6 bodova zaustavite mašinu na stop

3 odsecite višak konca

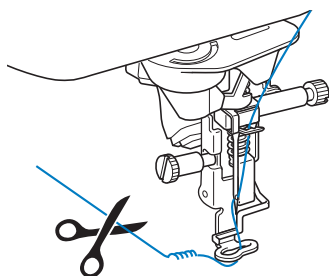

4 pritisnite start da nastavite vez

5 kada završite sa prvom bojom, uklonite je i nameštite sledeći konac

6 ponovite sve korake kao za prvu boju

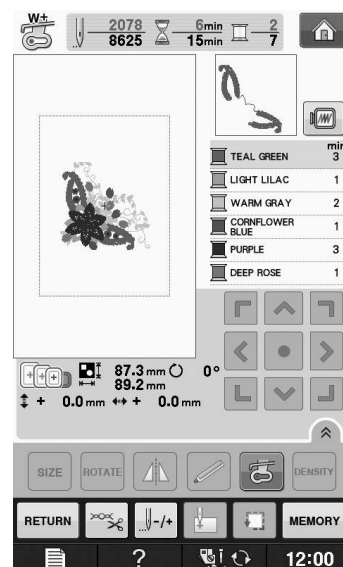

Šivenje vezenog dizajna kao aplikacija

postoji posebna vrsta veza, zvana aplikacija

1 pripegajte stabilizator na naličje

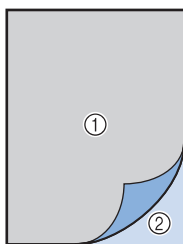

- ① aplikacijski material
- ② stabilizator

2 postavite aplikacijski material u ram i krenite na start

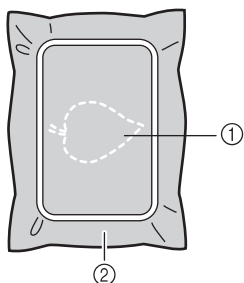

- ① ivice aplikacije
- ② material

3 uklonite aplikacijski material sa rama, a zatim pažljivo isecite po ivicama boda

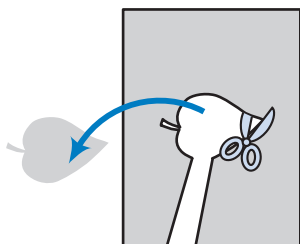

4 postavite osnovni material u ram

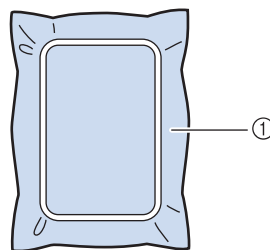

① osnovni material

5 pritisnite start da sašijete poziciju aplikacije

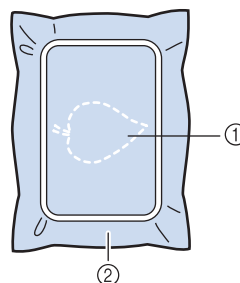

- ① pozicija aplikacije
- ② osnovni material

6 naprskajte malo lepka u spreju i postavite aplikaciju

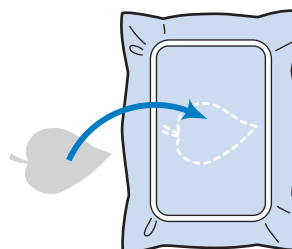

7 pritisnite start stop dugme

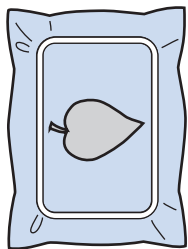

8 promenite gornji konac i sprovedite ostatak veza

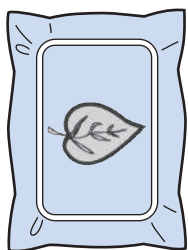

ako nestane donji konac

ako nestane donji konac, pojaviće se poruka.

pritisnite sledeći taster
i pratite uputstva dole



u retkim slučajevima ima još malo konca i
pritisanjem close možete da uradite par bodova

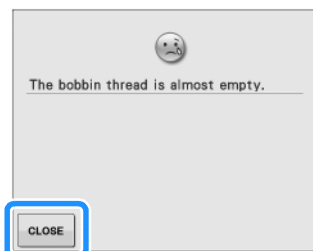

1

OK pritisnite

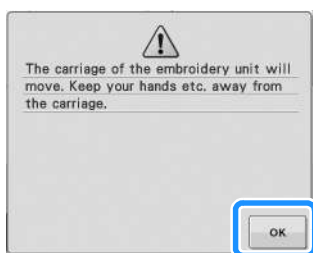

ako se konac automatski iseče,
vezna jedinica će se pomeriti

2

uklonite ram za vez, kako je ranije objašnjeno

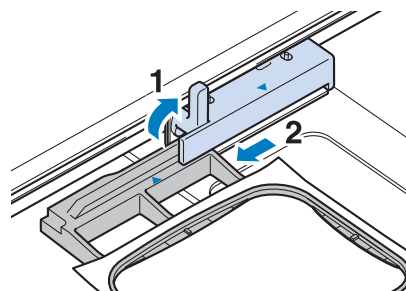

3

ubacite špulnu u mašinu

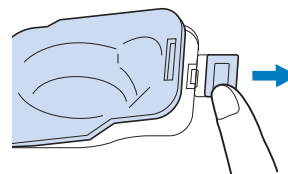

4

OK pritisnite

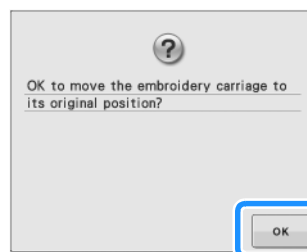

vezna jedinica će se vratiti u inicijalni položaj

5

prikačite ram

6





u sledećoj sekciji je objašnjeno kako da nastavite vez
gde je prekinut

AKO KONAC PUKNE ZA VREME VEZA

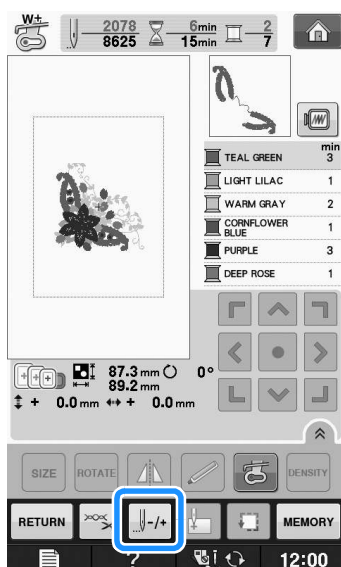
- 1 pritisnite start stop
- 2 namotajte ponovo gornji konac onako kako je opisano u uputstvu

3  pritisnite



4 pritisnite , , , ili 

da pomerite iglu u nazad tamo gde je vez prekinut

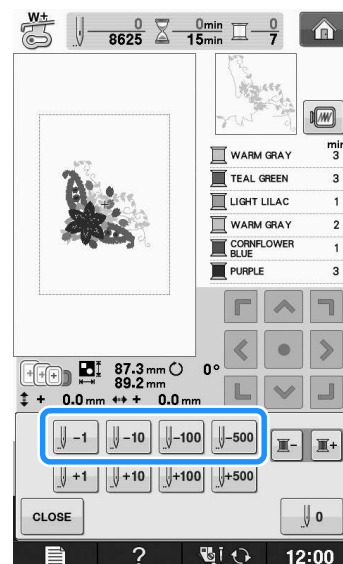

5  da se vratite na početni ekran

6 spustite stopicu i nastavite sa radom

VRAĆANJE NA POČETAK

1  pritisnite

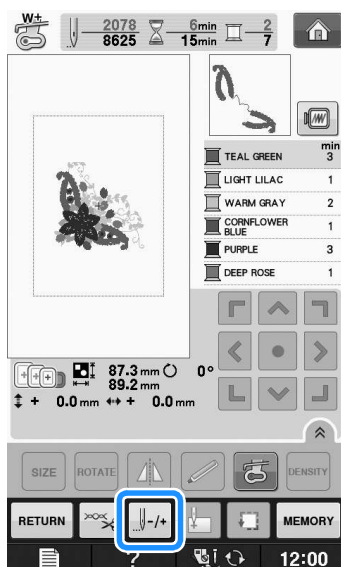

2  pritisnite

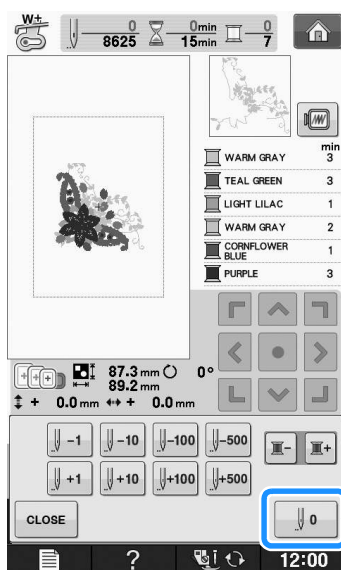

3 spustite stopicu i krenite sa radom

NASTAVLJANJE SA RADOM

Poslednja podešavanja će se sačuvati, tako da pri uključivanju mašine imate opciju da izaberete da li ćete raditi sve iz početka ili nastavljate sa započetim radom

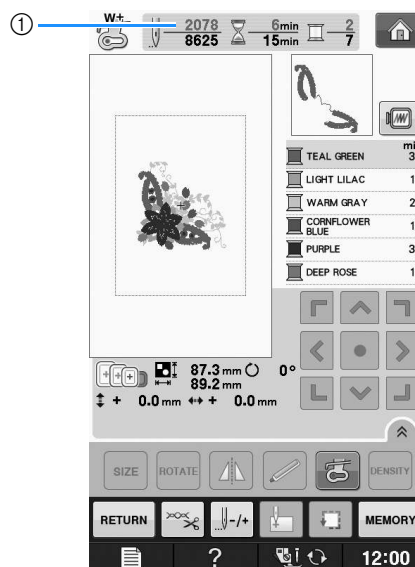

1 broj boda gde je vez stao

1 uključite mašinu

2 pratite uputstva i pomerite ram za vez

3 prikačite ram i pritisnite

OK

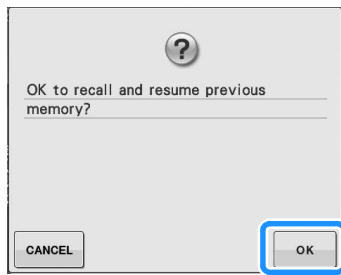
**4** nastavak veza

①

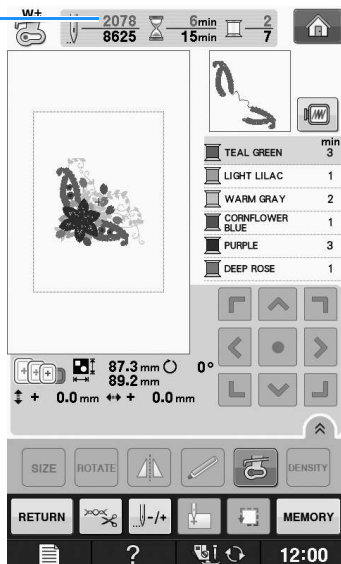

① broj boda odakle vez nastavlja

PODEŠAVANJA

PODEŠAVANJE NAPETOSTI KONCA

- Ispravna napetost konca
dizajn mora lepo da se vidi na naličju



- ① lice
- ② naličje

ukoliko se ne vidi lepo, pratite uputstva dole,
da podesite napetost konca

- gornji konac je previše zategnut

ukoliko je gornji konac previše zategnut,
konac špulne će se videti na licu

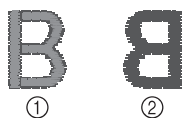

- ① lice
- ② naličje

- 1  pritisnite

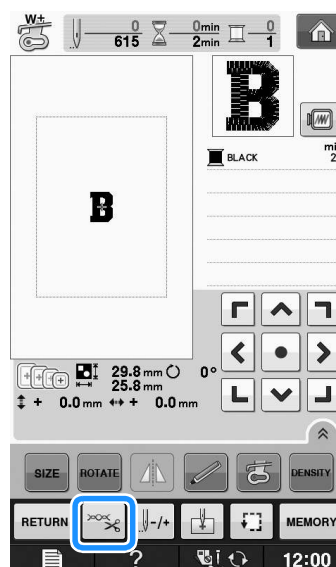

- 2 pritiskajte - da smanjite tenziju

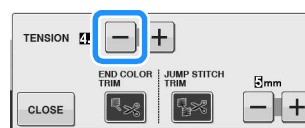

- 3  pritisnite

- gornji konac je labav

labav gornji konac uzrokuje preskakanje bodova
i ostavljanje praznina na vezu

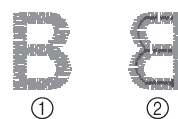

- ① lice
- ② naličje

- 1  pritisnite

2 pritiskajte na + da povečate tenziju

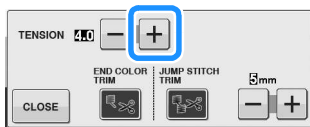

3 .pritisnite

na + ili - se vrše podešavanja

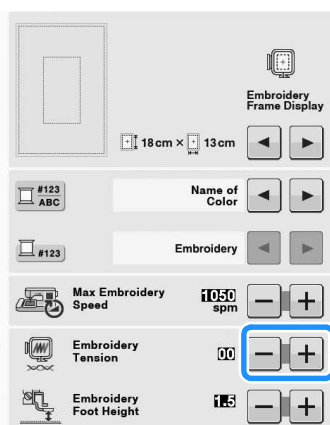

podešavanja grajfera

podešavanja na grajferu, koja se tiču zategnutosti, postoje obzirom na različite vrste konaca.

da podesite napetost, upotrebite mali šrafciğer

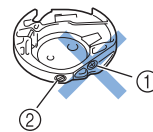

- ① ne ubacajte bilo kakav šrafciğer
- ② mali šrafciğer

- ispravna napetost
- konac seuredno prikazuje sa obe strane

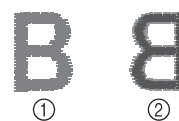

- ① lice
- ② naličje

- konac špulne je labav
- konac špulne se pojavljuje na licu

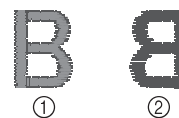

- ① lice
- ② naličje

okrenite šraf u smeru kazaljke na satu ka - (minus)

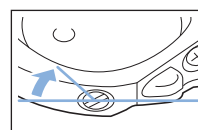

- konac špulne je prezategnut
-videće se ispadanje bodova i rupice na naličju



- ① lice
- ② naličje

ako se ovo desi, okrenite šraf u smeru
suprotno od sata za 35,40 stepeni

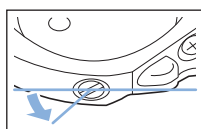



KORIŠĆENJE AUTOMATSKOG SEKAČA

funkcija automatskog sečenja  je inicijalno uključena. ako hoćete da isključite,

pritisnite  i a zatim .

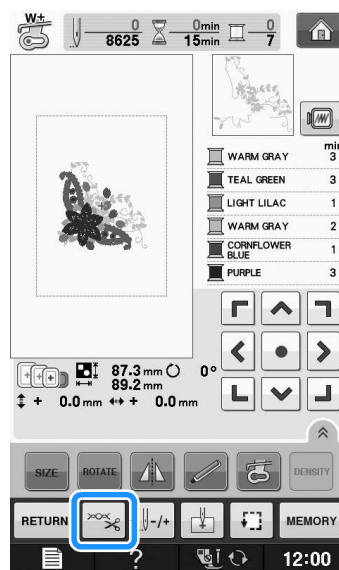
- 1  pritisnite



- 2  pritisnite da isključite funkciju



KORIŠĆENJE FUNKCIJE PRESKAKANJA BODOVA

ova funkcija je takođe inicijalno uključena,
a za isključivanje pratite iste korake kao
na prošloj funkciji

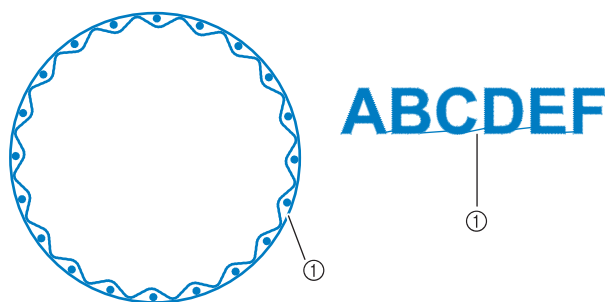

- ① preskakanje

1

 . pritisnite

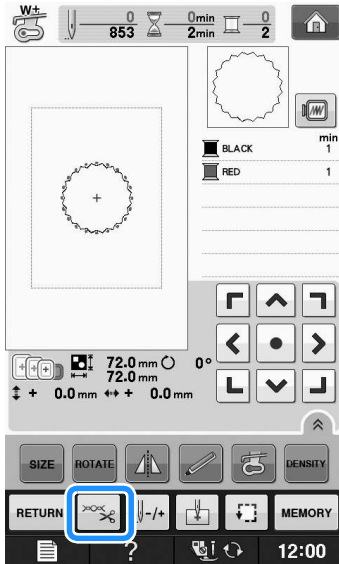

2

 pritisnite da isključite funkciju



■ podesite dužinu boda koji ne želite da isečete

podešavajte dužinu preskoka na + ili -.

primer: podesite 1 inč i toliki preskokneće biti isečen

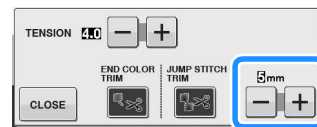

PODEŠAVANJE BRZINE VEZA

1

 . pritisnite

2

podešavajte na + ili -

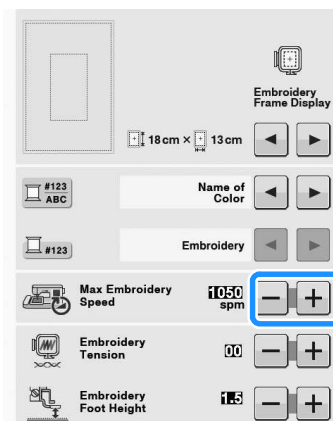

PROMENA BOJE KONCA EKRANA

na ekranu možete da menjate broj i naziv konca

1  pritisnite

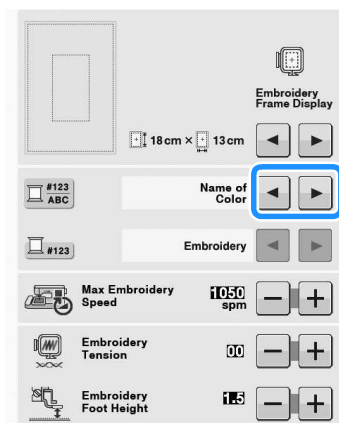

2 koristite strelice za promene

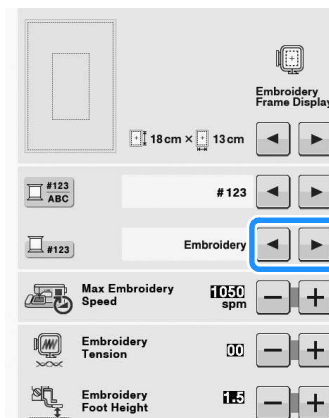

3 koristite strelice i menjajte neki od naziva brendova koji su navedeni dole





**EMBROIDERY / POLYESTER
THREAD#**

-  509 Embroidery
-  804 Embroidery
-  085 Embroidery



COUNTRY/COTTON THREAD#*

-  463 Country
-  604 Country
-  155 Country



**MADEIRA /POLYESTER
THREAD#**

-  1749 Madeira Poly
-  1630 Madeira Poly
-  1921 Madeira Poly



MADEIRA RAYON THREAD#

-  1050 Madeira Rayon
-  1261 Madeira Rayon
-  1108 Madeira Rayon

SULKY THREAD#

-  1510 Sulky
-  1193 Sulky
-  1224 Sulky

**ROBISON-ANTON/POLYESTER
THREAD#**

-  5514 R-A Poly
-  5586 R-A Poly
-  5523 R-A Poly

4  pritisnite

PROMENA RAMA NA EKRANU

1  pritisnite

2 koristite strelice za promene

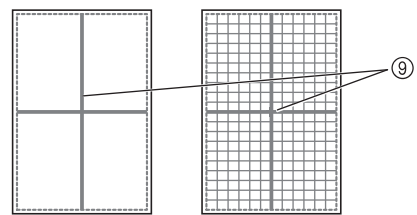
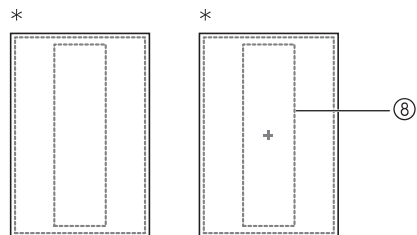
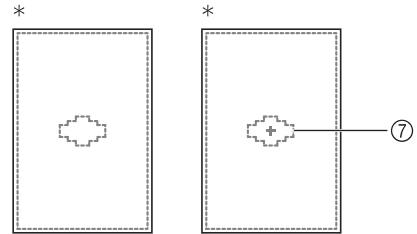
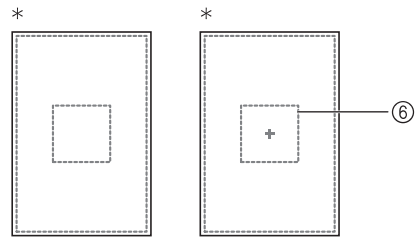
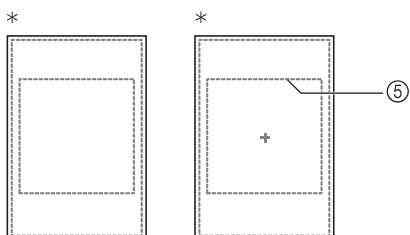
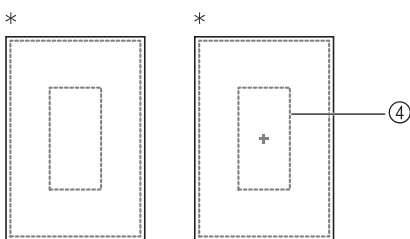
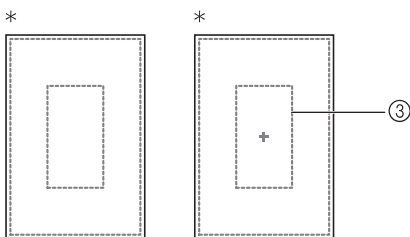
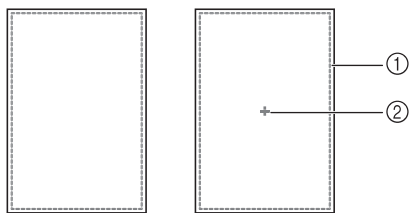
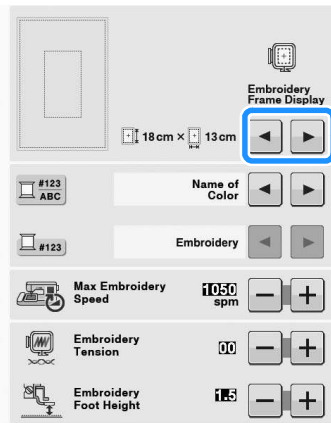

- ① ram sa dimenzijama 30 cm x 18 cm (12 inches x 7 inches)
- ② centar
- ③ ram sa dimenzijama 18 cm x 13 cm (7 inches x 5 inches)
- ④ ram sa dimenzijama 18 cm x 10 cm (7 inches x 4 inches)
- ⑤ ram sa dimenzijama 15 cm x 15 cm (6 inches x 6 inches)
- ⑥ ram sa dimenzijama 10 cm x 10 cm (4 inches x 4 inches)
- ⑦ ram sa dimenzijama 2 cm x 6 cm (1 inch x 2-1/2 inches)
- ⑧ ram sa dimenzijama 30 cm x 10 cm (12 inches x 4 inches)
- ⑨ linije mrežice

3  pritisnite

POMERANJE DIZAJNA



koristite strelice za pomeranje



pritisnite za centar

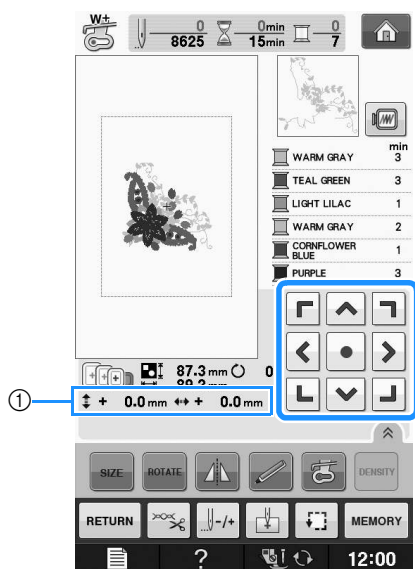

① udaljenost od centra

dizajn takođe možete da pomerate
i uz pomoć miša

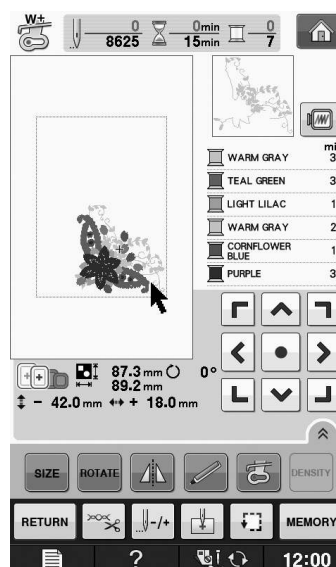

IZJEDNAČAVANJE DIZAJNA I IGLE

Primer: leva strana dizajna i igla

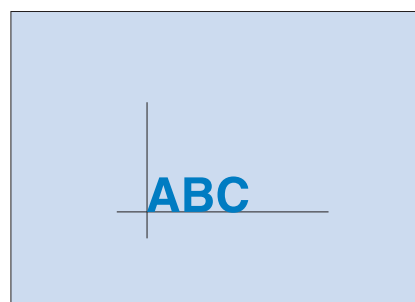

1 obeležite startnu poziciju

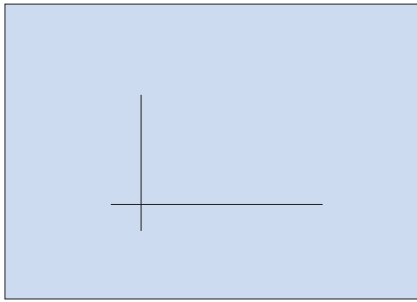

2  .pritisnite

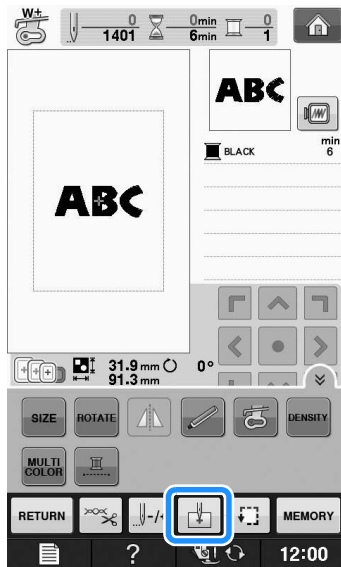

3  . pritisnite

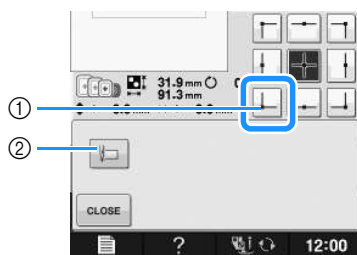

- ① startna pozicija
- ② taster za izjednačavanje

4  .pritisnite

5  koristite strelice za izjednačavanje

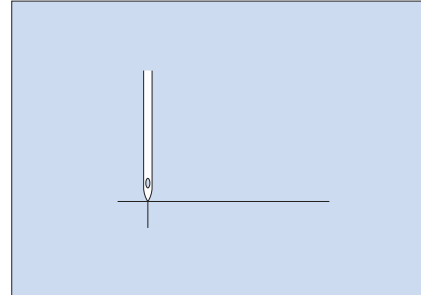





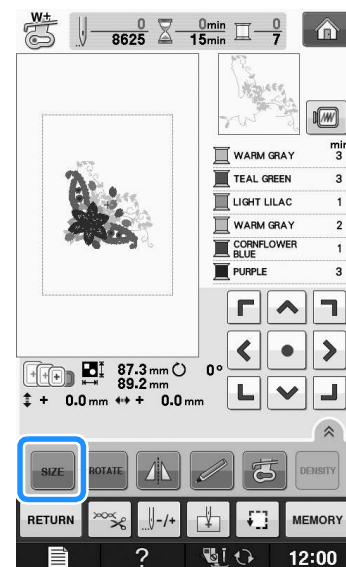

PROMENA VELIČINE DIZAJNA

1  .pritisnite



2 odaberite smer u kome želite da menjate veličinu

- *  da uvećate proporcionalno
- *  da sakupite proporcionalno
- *  da razvučete horizontalno
- *  da sabijete horizontalno
- *  da razvučete vertikalno
- *  da sabijete vertikalno
- *  da vratite na originalnu veličinu

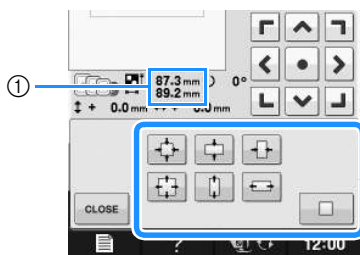

① veličina

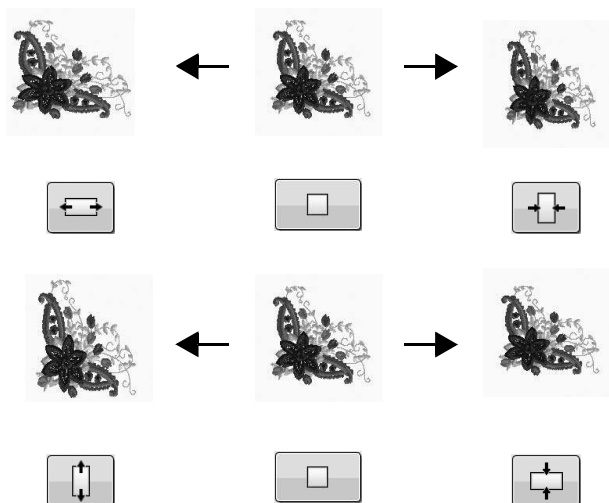





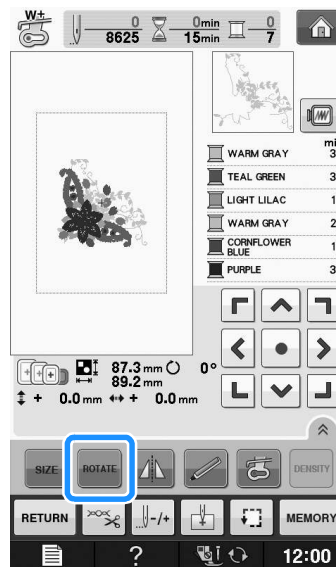

③ **CLOSE** da se vratite na početni ekran

ROTACIJA DIZAJNA

① **ROTATE** pritisnite



② izaberite ugao rotacije

- *  za 90 stepeni levo
- *  za 90 stepeni desno
- *  za 10 stepeni levo
- *  za 10 stepeni desno
- *  za 1 stepen levo
- *  za 1 stepen desno
- * **RESET** za vraćanje na početnu poziciju

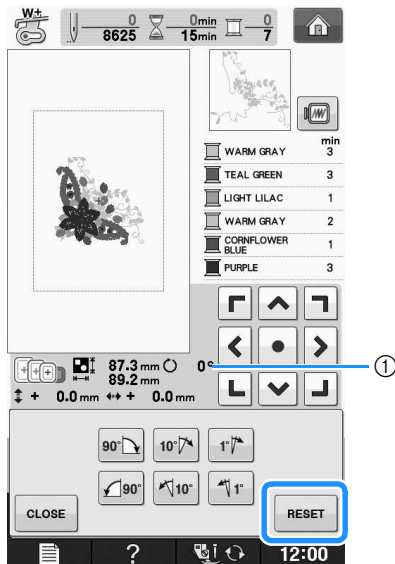

① ugao rotacije



3 **CLOSE** da se vratite na početni ekran

HORIZONTALNO OGLEDALO

pritisnite i pojavi se da kreirate izgled kao u ogledalu

pritisnite opet da se vratite na normalno

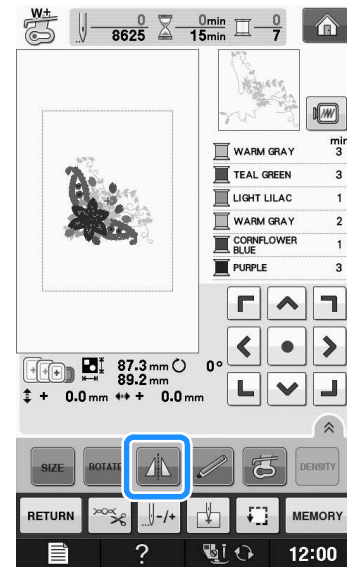

UVEĆAVANJE EKRANA

za uvećavanje ekrana pritisnite .



da zatvorite uećani ekran



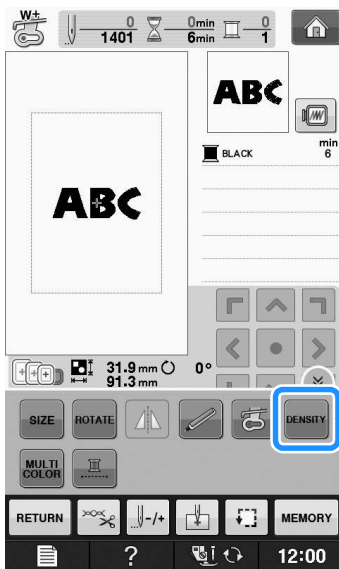

PROMENA GUSTINE

1  pritisnite



2 promena gustine

- *  za ređe
- *  za gušće

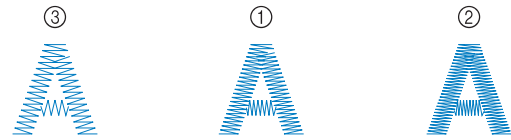
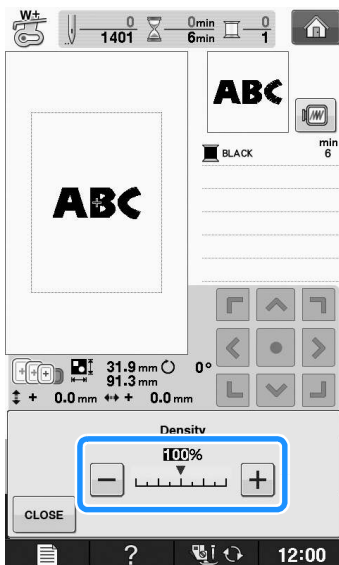

- ① normalno
- ② gušće
- ③ ređe

3  da se vratite na početni ekran

PROMENA BOJE SLOVA

1 pritisnite  i pojavi se .

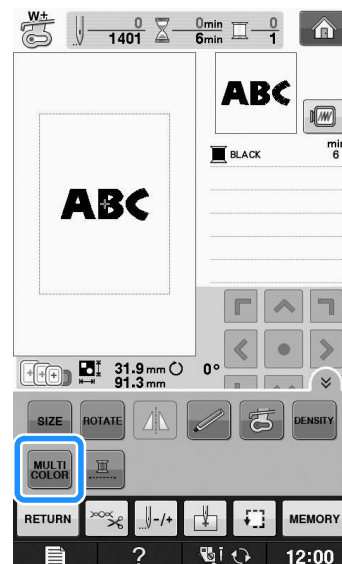

2 kada se završi jedno slovo, promenite konac i uradite drugo

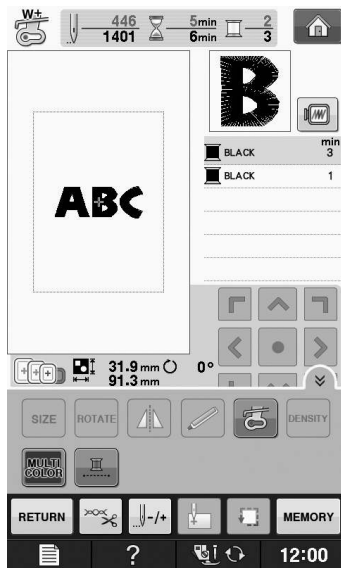

VEZ POVEZANIH KARAKTERA

pratite sledeću proceduru

Primer: povežite "DEF" sa "ABC"

A B C D E F

1 selektujte karaktere "ABC".

2  pritisnite

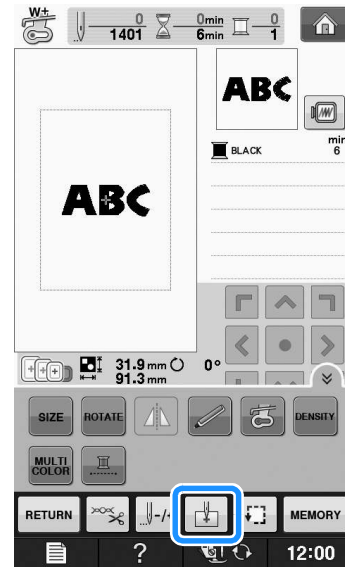

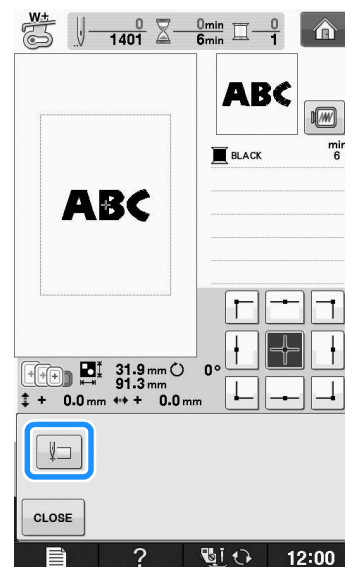

3  pritisnite

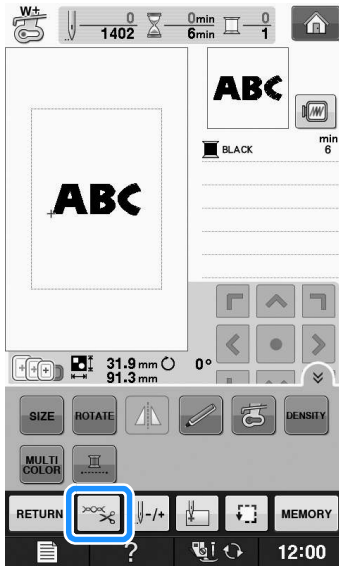

4  . pritisnite

5  . pritisnite



6  pritisnite da isključite sečenje konca a zatim pritisnite  .

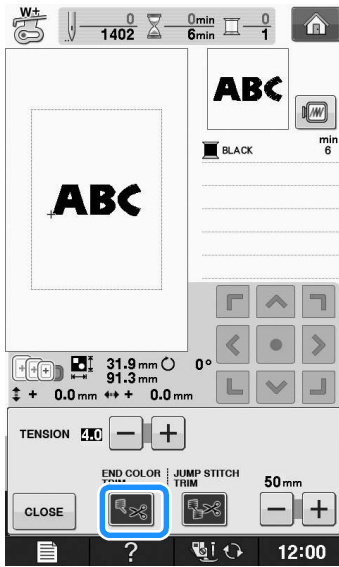

7 pritisnite start stop dugme

8 kada se vez završi, odsecite konac na uobičajenu dužinu, otklonite ram, a zatim namestite ponovo i započnite vez sledeće sekcije

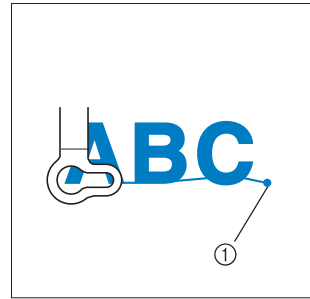

① kraj veza

9 kao i u ¹ koraku, sada izaberite "DEF".

10  . pritisnite

11  . pritisnite

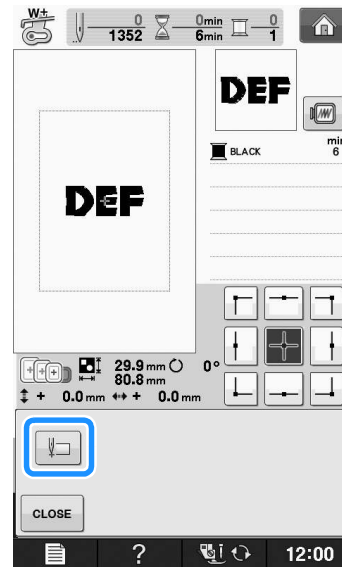

12 pritisnite  .

13



koristite strelice da izjednačite iglu sa početkom sledećeg veza

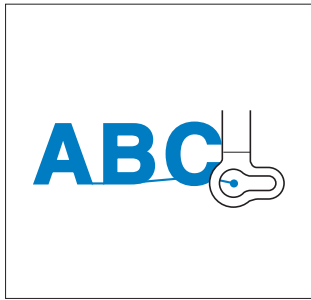

14

pritisnite start stop dugme da nastavite



VEZ U JEDNOJ BOJI; BEZ PREKIDA

karaktere možete da vezete i samo u jednoj boji

kada završite sekvencu, samo pritisnite  i vez će biti nastavljen u istoj boji

pritisnite zatim  ako želite da vratite podešavanja

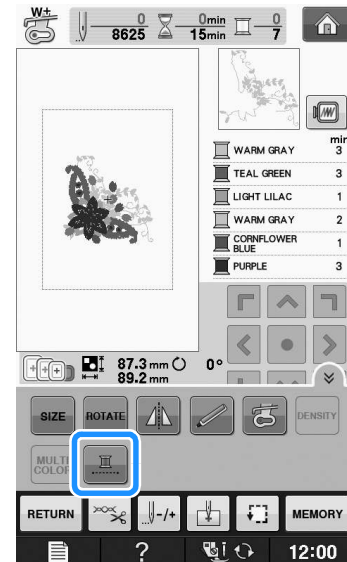

boja konca na ekranu će posiveti

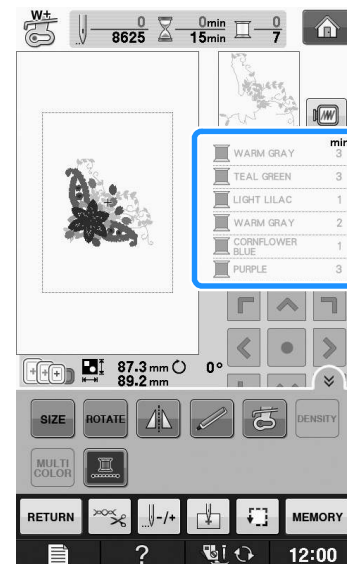

MERE PREDOSTROŽNOSTI

vodite računa o sledećim uputstvima o merama predostrožnosti, kada su u pitanju podešavanja dizajna i njihovo čuvanje.

■ tipovi dizajna koji mogu da se koriste

.pes, .phc, i .dst

su jedini kompatibilni sa vašom mašinom

■ tipovi USBa koji mogu da se koriste

- USB Flash drive (USB Flash memory)
- USB Floppy disk drive
- USB CD-ROM, CD-R, CD-RW

pored toga, možete da koristite i

- Secure Digital (SD) Card
- CompactFlash
- Memory Stick
- Smart Media
- Multi Media Card (MMC)
- XD-Picture Card

■ kompatibilni kompjuteri i operativni sistemi

kompjuteri

IBM PC

operativni sistemi

Microsoft Windows XP, Windows Vista, Windows 7

- nemojte da pravite foldere na USBu, mašina dizajn tako neće prepoznati

■ Tajima (.dst)

na ekranu se neće prikazati slika dizajna, već samo naziv.
naziv se vidi samo u obliku početnih 8 karaktera

ČUVANJE DIZAJNA NA MAŠINI

vaš podešen dizajn možete da sačuvate na memoriji mašine na sledeći način

1 pritisnite kada ste dobili zadovoljavajući izgled i podešavanja dizajna

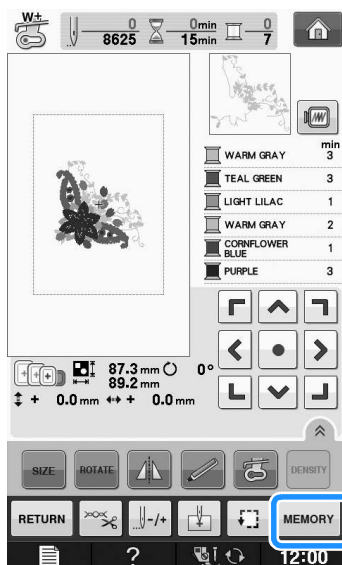

2 pritisnite da sačuvate

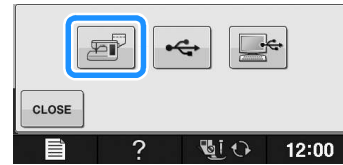

■ ako je memorija puna

1 pritisnite

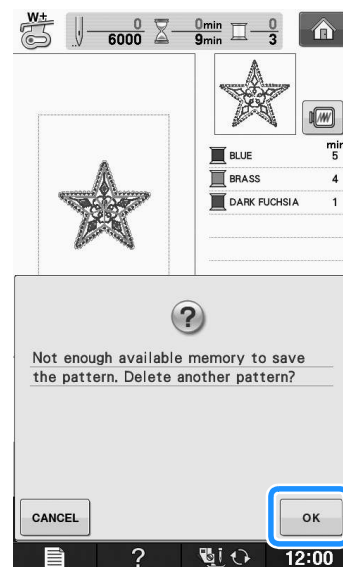

2 selektujte dizajn koji želite da izbrisete

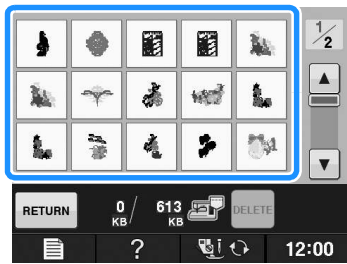

3 pritisnite **DELETE**

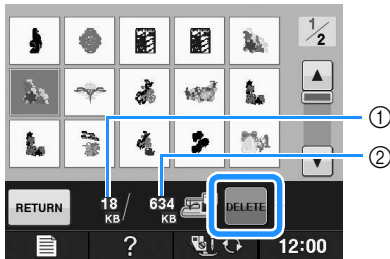

① broj koji želite da izbrisete

② broj koji čuvate

4 **OK** pritisnite

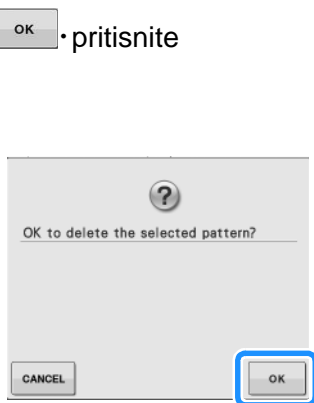

ako ne želite da izbrisete, pritisnite cancel

ČUVANJE DIZAJNA NA USBu

podešen dizajn možete da sačuvate na USBu

1 **MEMORY** pritisnite

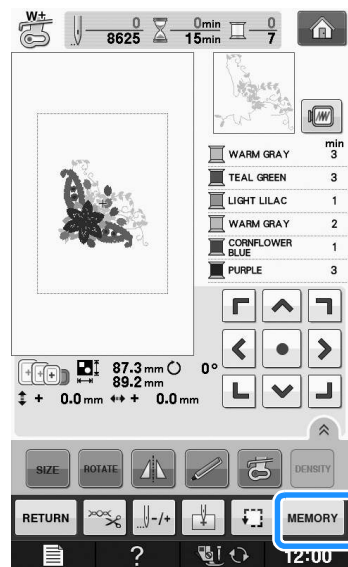

2 ubacite usb

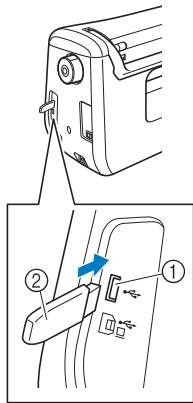

①ulaz
②USB

3  pritisnite



ČUVANJE NA KOMPJUTERU

povezivanjem sa kablom, možete direktno da čuvate dizajn na kompjuteru

1 ubacite kabl u mašinu i u kompjuter

2 uključite kompjuter i izaberite My computer

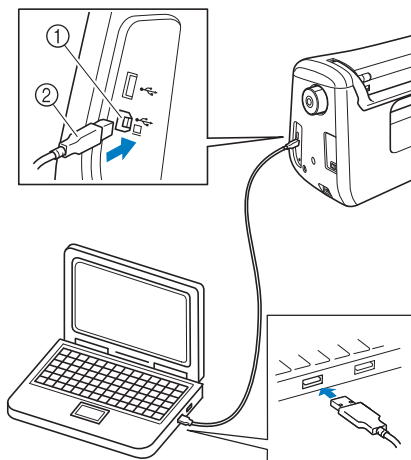

① ulaz
② USB kabl

3 MEMORY pritisnite

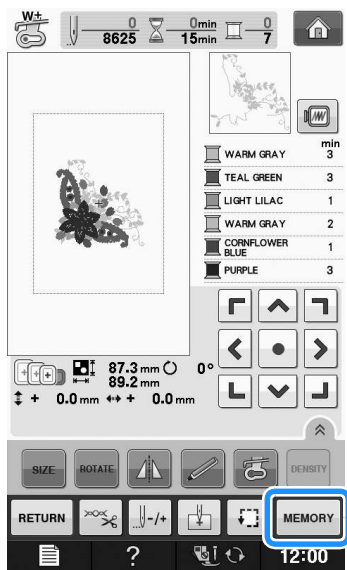

4 .pritisnite



5 selektujte .phc fajl sa "removable disk" i sačuvajte na kompjuteru

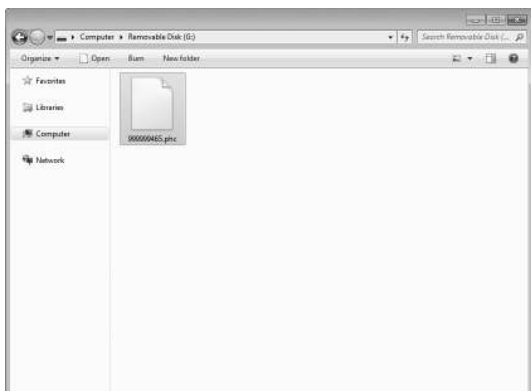

VRAĆANJE DIZAJNA

1 .pritisnite



2 kliknite na dizajn koji želite da vratite

*

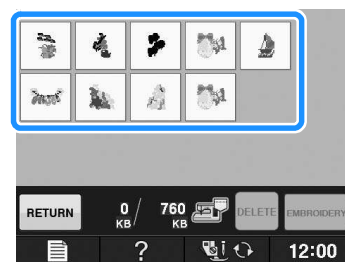

3 EMBROIDERY pritisnite

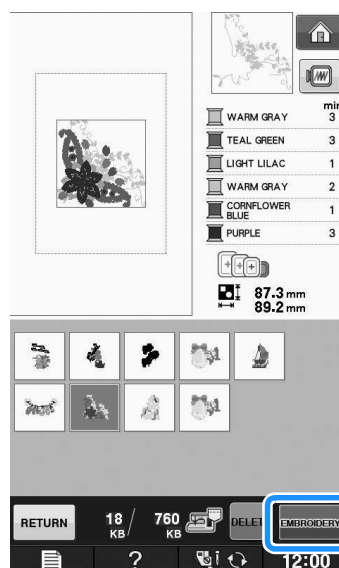

VRAĆANJE SA USBa

možete da povratite vaš dizajn sa usba

1 ubacite usb

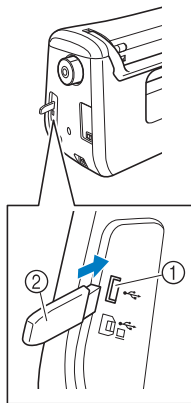

1 ulaz
2 USB

2  pritisnite



3  pritisnite da uđete u podfolder

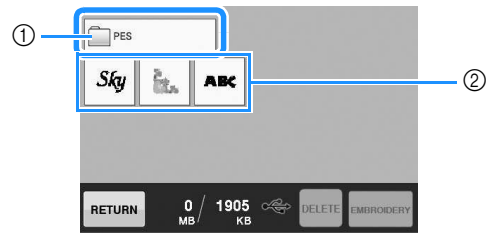

1 naziv
2 dizajn
3 putanja

 pritisnite ako želite da se vratite

4 pritisnite kada želite da vratite

RETURN za početni ekran

5 **EMBROIDERY** pritisnite

DELETE pritisnite da izbrisete dizajn sa usba

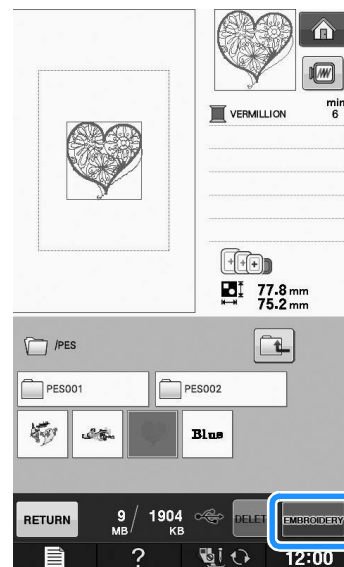

VRAĆANJE SA KOMPJUTERA

- 1 ubacite kabl u kompjuter i u mašinu
- 2 na kompjuteru otvorite "Computer (My computer)" pa idite na "Removable Disk".

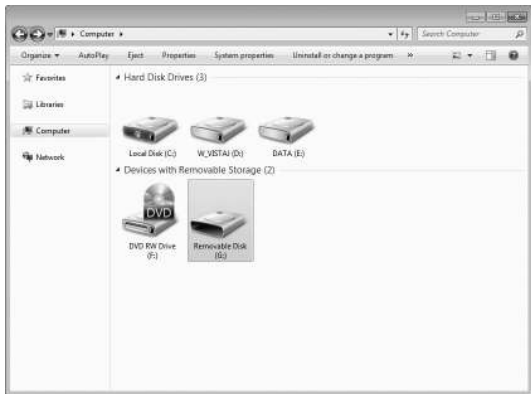

- 3 Move/copy dizajn na "Removable Disk".

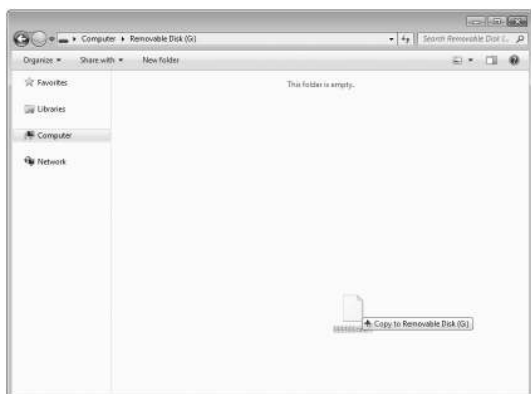

- 4  . pritisnite

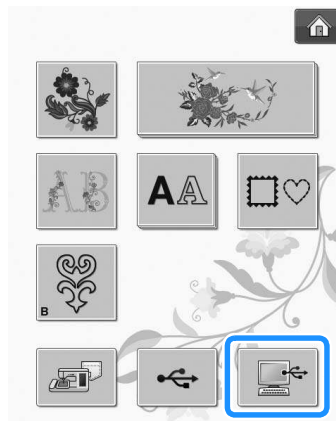

- 5 kliknite na dizajn koji želite da vratite

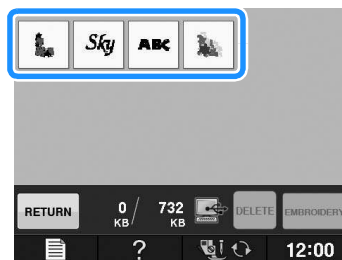

- 6  . pritisnite



APLIKACIJE

E
1

Embroidery

koristite ram da napravite aplikacije

- 1 izvezite dizajn na materijalu, a zatim odsecite viškove materijala po ivicama

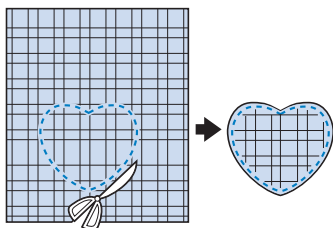
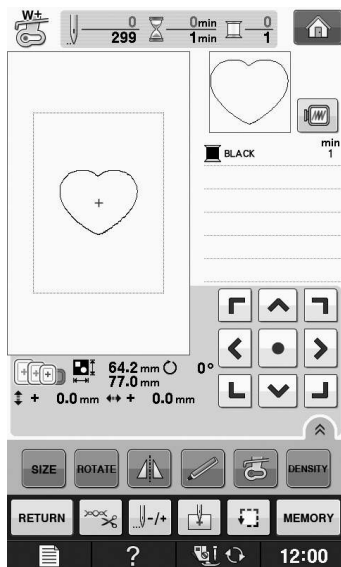

- 2 izvezite još jednom dizajn od koraka 1

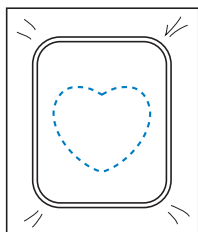

- 3 uz malo lepka u spreju, prilepite aplikaciju na bazni materijal

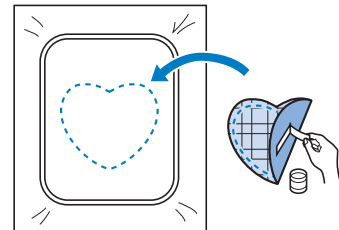

- 4 izaberite saten bodi i vezite od koraka 3 da izradite aplikaciju

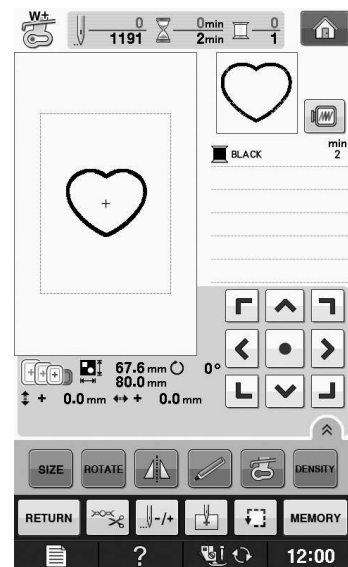

UPOTREBA DIZAJNA OKVIRA ZA APLIKACIJE

ovo je druga metoda izrade aplikacije

- 1 izaberite ravan bod dizajna okvira i izvezite ga na osnovnom materijalu

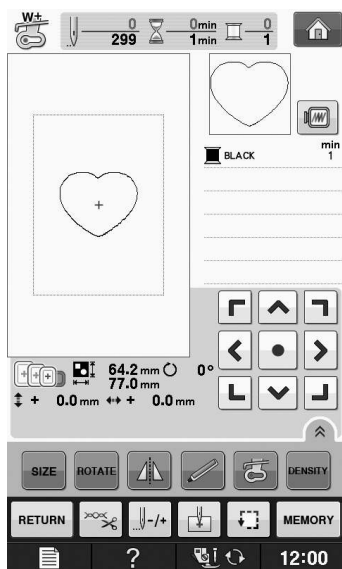

- 2 postavite aplikacijski materijal i izvezite opet od koraka 1.

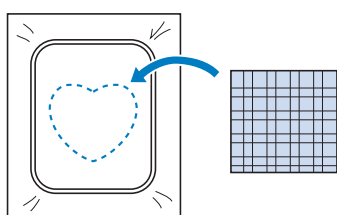

- 3 vezite isti dizajn na aplikacijskom materijalu

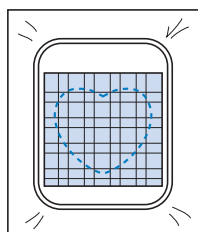

- 4 uklonite ram i isecite višak materijala

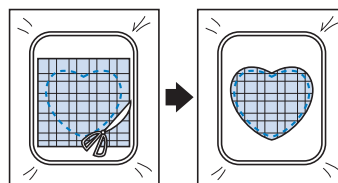

- 5 izaberite saten bod dizajna za istu aplikaciju

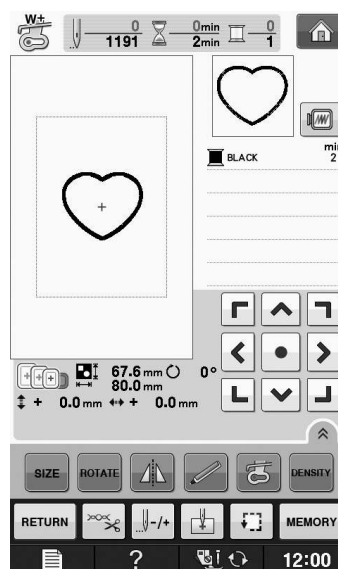

- 6 namestite ponovo ram i izradite saten bod da završite aplikaciju

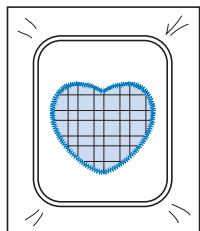

IZRADA ODVOJENIH DIZAJNA

možete da koristite program
PE-DESIGN ili PE- DESIGN NEXT
za odvojene dizajne

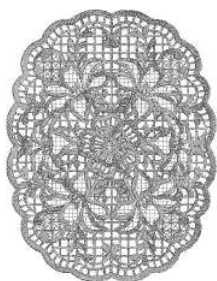

- 1 mašinu povežite sa uređajem gde ste sačuvali odvojeni dizajn

*

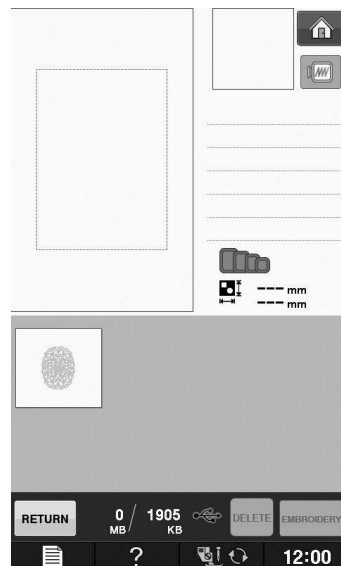

- 2 odaberite ovu  sekciju

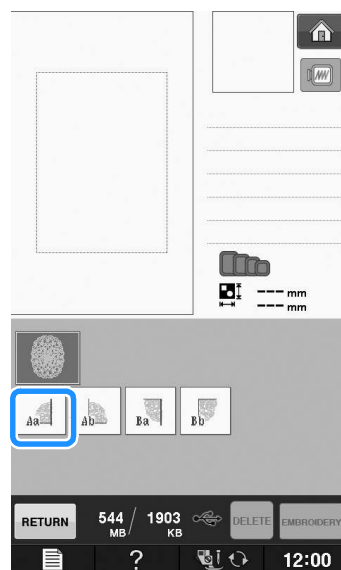

3

EMBROIDERY • pritisnite

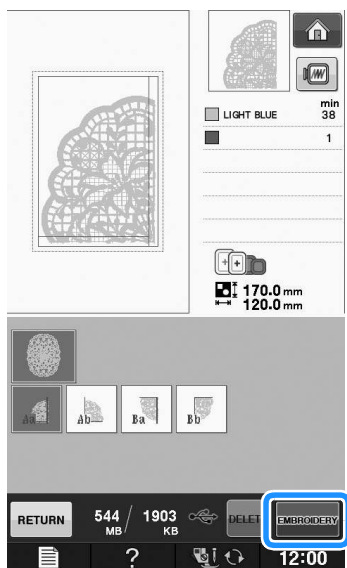

4 ako je potrebno, podesite dizajn

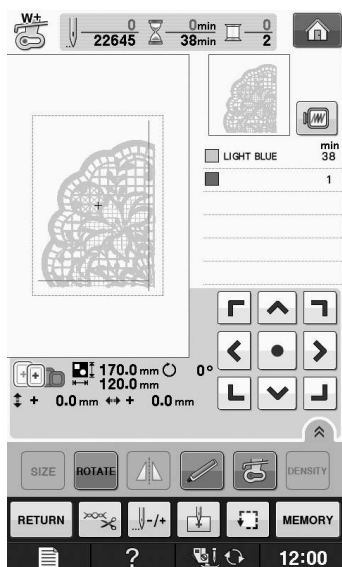

5

pritisnite start stop dugme da izvezete sekciju

6

kada završi, pritisnite ok

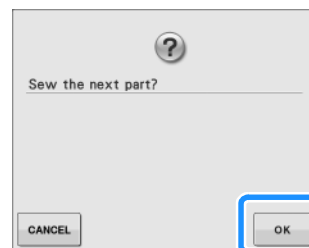

7

ponovite korake od 2 do 6 da izvezete ostale sekcije

PODEŠAVANJA VEZA

Objašnjenje funkcija.....	57
Selektovanje dizajna za podešavanje	58
Selektovanje „Exklusives“ bodova za podešavanje.....	59
Selektovanje slova.....	59
Podešavanja.....	61
■ Operativni tasteri.....	62
Pomeranje dizajna	63
Rotacija.....	63
Promena veličine.....	63
Brisanje	63
Prikazivanje dizajna 200%	63
Promena konfiguracije	64
Promena razmaka.....	64
Redukovanje razmaka	65
Odvojeno kombinovanje karaktera	65
promena boje svakog slova	66
vez povezanih karaktera.....	67
Promena boje konca	67
Kreiranje table boje konca.....	68
■ Dodavanje boje na tablu	69
■ Čuvanje uobičajene table na usbu	70
■ Vraćanje podešavanja sa usba	70
Odabir boja iz table	71
Dizajniranje ponovljenih uzoraka	72
■ Šivenje	72
■ Ponavljanje jednog elementa.....	74
■ Sortiranje boja	75
■ Određivanje marke konca	75
Vež u više navrata.....	76
Duplikati.....	78
Posle podešavanja.....	79
Kombinovanje dizajna.....	80
Podešavanje kombinovanog dizajna.....	80
■ Selektovanje kombinovanog dizajna	82
Šivenje kombinovanog dizajna	83
Različite funkcije veza.....	84
Jednobožno neprekinuto vezenje.....	84
Firc vez.....	84
Upotreba memorijskih funkcija.....	85

Ovo poglavlje će vam pomoći da koristite razne funkcije

- kombinovanje dizajna
- pomeranje dizajna
- rotacija dizajna
- uvećajte da redukujete dizajn
- slika kao u ogledalu
- promena razmaka kod slova
- promena pravca slova, horizontalno ili vertikalno
- promena boje konca
- ponavljanje dizajna, duplikati



ODABERITE DIZAJN KOJI ĆETE PODEŠAVATI

pritisnite

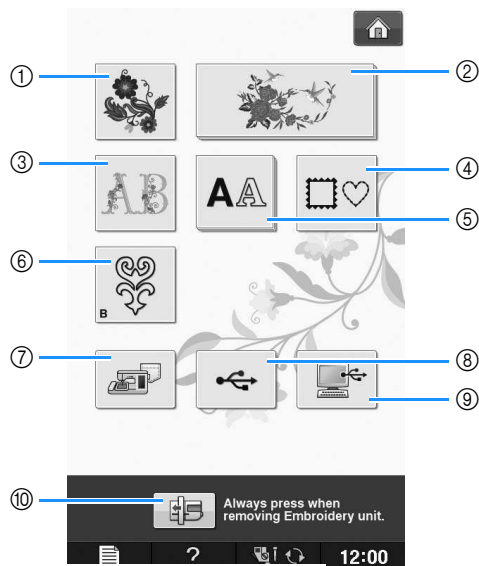

- ①
- ②
- ③ floralna slova
- ④ okviri
- ⑤ karakteri
- ⑥ rad sa špulnom
- ⑦ dizajn koji ste sačuvali na memoriji mašine
- ⑧ dizajn koji ste sačuvali na usbu
- ⑨ dizajn koji ste sačuvali na kompjuteru
- ⑩ pritisnite za pozicioniranje vezne jedinice

ODABIR: **Brother**
**“Exclusives”/Floral Alphabet
 Patterns/Frame/Bobbin Work
 Patterns**

- 1 odaberite kategoriju dizajna
- 2 kliknite na dizajn koji želite da podešavate

- 3 **SET** pritisnite

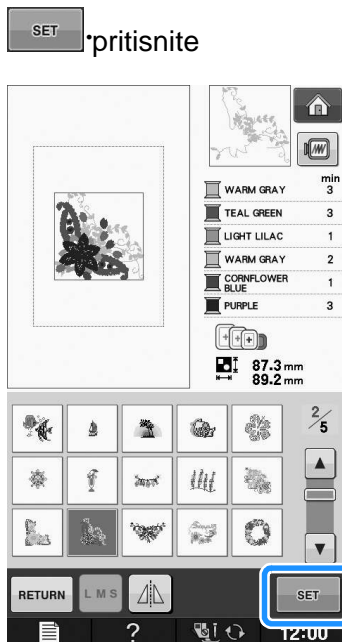

- 4 nastavite na “EDITING PATTERNS”

SELEKTOVANJE SLOVA

- 1 **AA** pritisnite



- 2 izaberite font, a zatim unesite karaktere

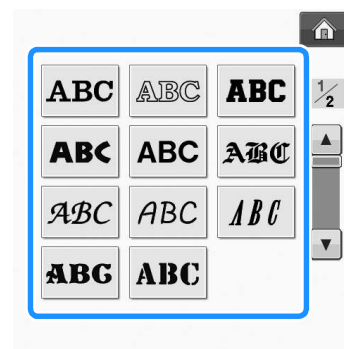

3

ARRAY pritisnite da promenite pravac kretanja

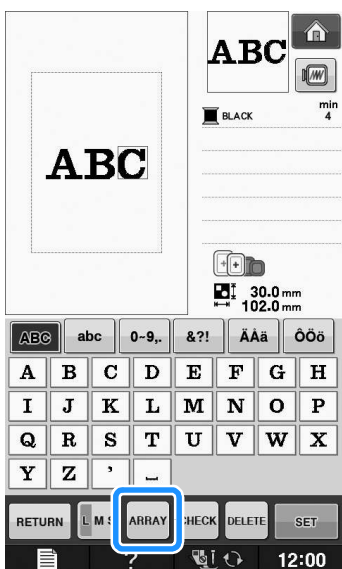

4 izaberite pravac ↗ (primer : ↗)

kada izaberete ↗, ↶ ili ↷

promenite na ↘ ili ↙.

možete da povećavate ili smanjujete nagib

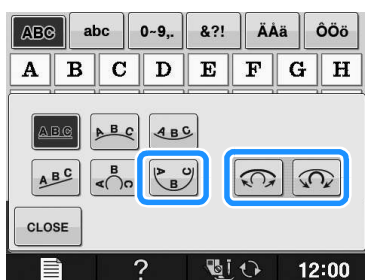

5

CLOSE da se vratite na početni ekran

6

SET pritisnite kada završite

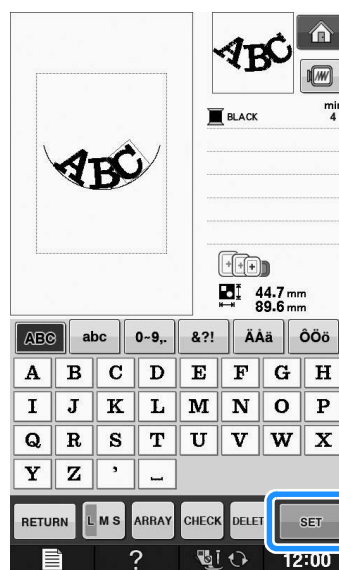

7 nastavite na "EDITING PATTERNS"

UREĐIVANJE, PODEŠAVANJE DIZAJNA

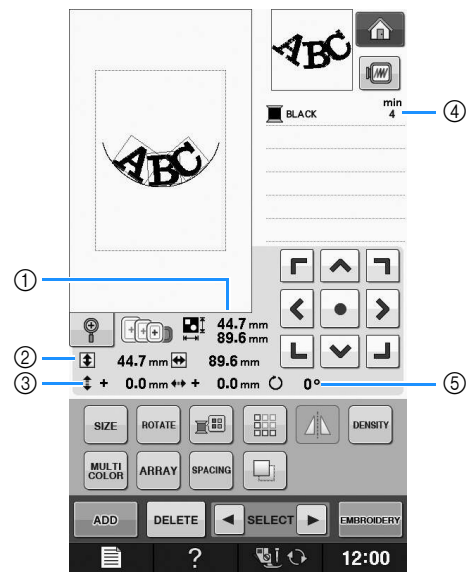
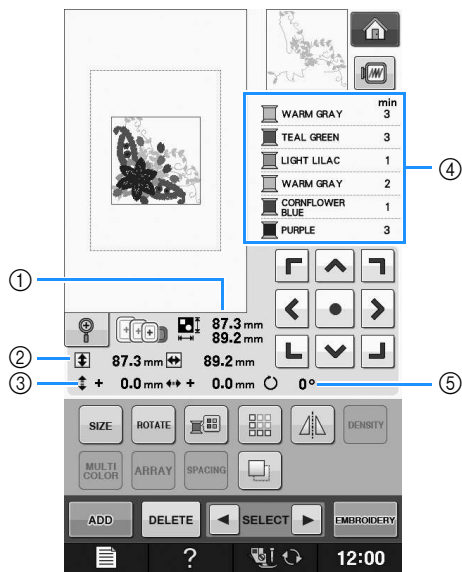
E
2

- ① prikazuje veličinu celog dizajna
- ② prikazuje veličinu sekvence
- ③ prikazuje razmak između centra i rama
- ④ prikazuje boju sekvenci
- ⑤ prikazuje rotaciju

■ funkcije

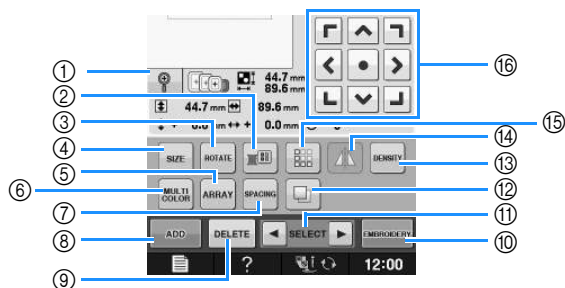

①		uvećanje
②		paleta konca rotacija
③		rotacija
④		veličina
⑤		niz
⑥		više boja
⑦		razmak
⑧		dodavanje
⑨		brisanje
⑩		razmak
⑪		selektovanje
⑫		duplikati
⑬		gustina
⑭		ogledalo
⑮		granice
⑯		strelice (● centar)

- _____
- POMERANJE
- _____
- ZA DETALJE STRANA 36
- _____
- ROTACIJA
- _____
- ZA DETALJE STRANA 38
- _____
- PROMENA VELIČINE
- _____
- ZA DETALJE STRANA 37
- _____
- BRISANJE

DELETE pritisnite

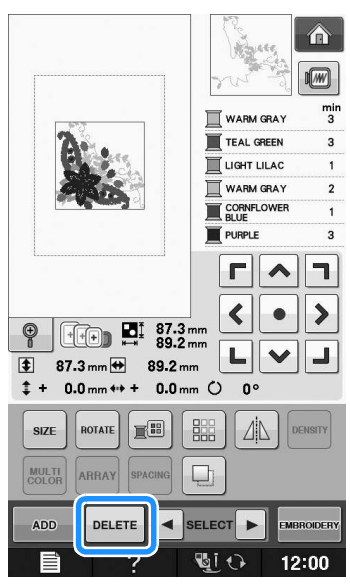

200% UVEĆANO

1

pritisnite

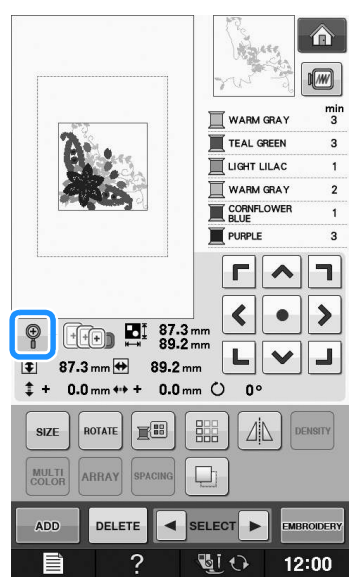

2

proverite prikazan dizajn

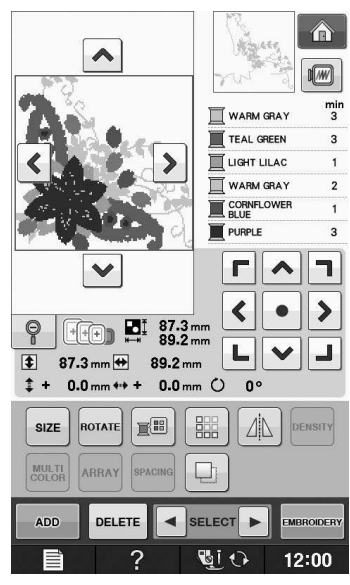

3

da se vratite na normalan prikaz od 100% pritisnite



PROMENA KONFIGURACIJE

1 ARRAY pritisnite

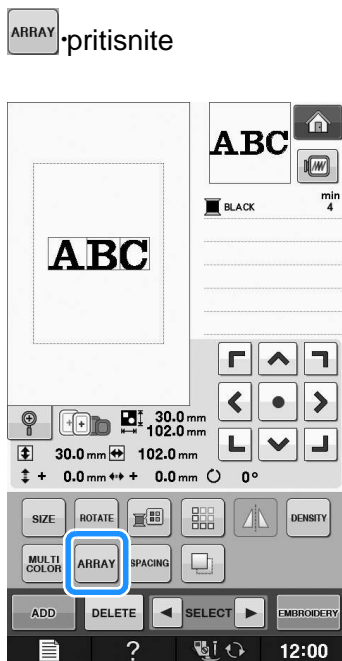

2 pritisnite na ikonicu na odgovarajući nagib

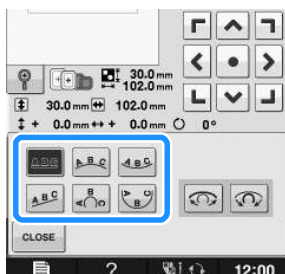

3 CLOSE pritisnite



PROMENA RAZMAKA

1 SPACING pritisnite

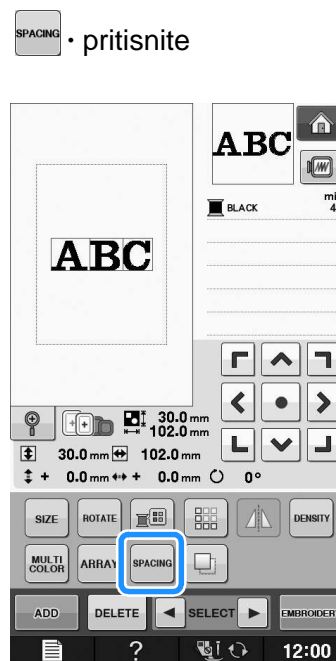

2 pritisnite DA PROMENITE RAZMAK

←ABC→ pritisnite da povećate

→ABC← pritisnite da smanjite

A.B.C pritisnite da vratite na originalno

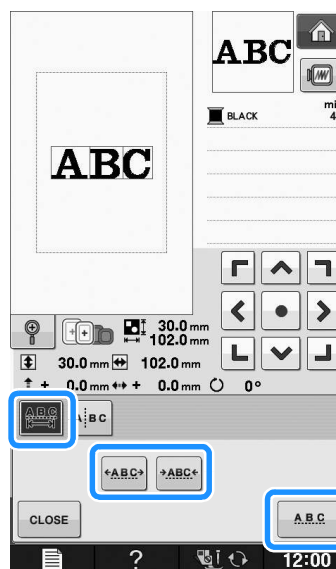

A B C ↔ A B C

←ABC→

→ABC←

3 CLOSE pritisnite da vratite na početni ekran

CLOSE

REDUKOVANJE RAZMAKA

razmak možete dodatno redukovati

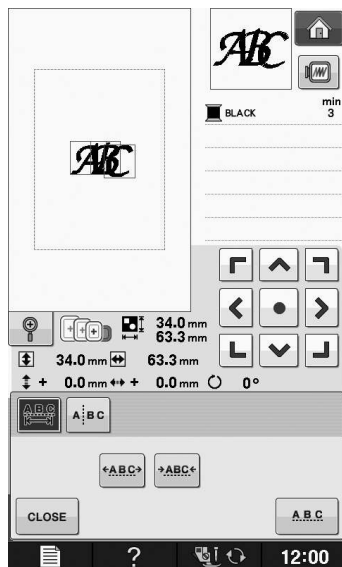
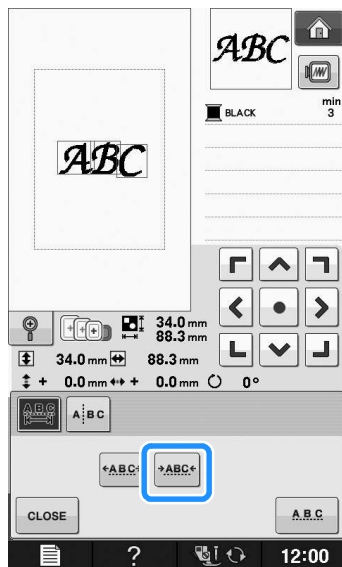

ODVAJANJE KOMBINOVANIH KARAKTERA

1

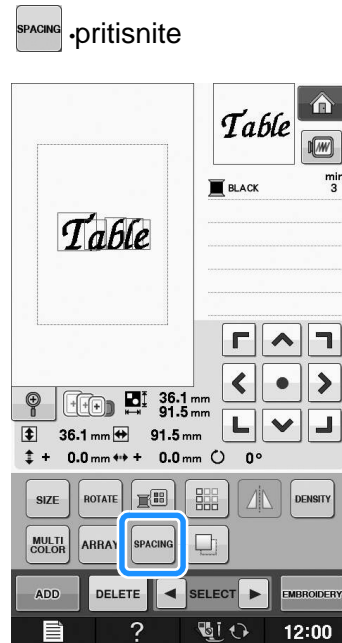

2

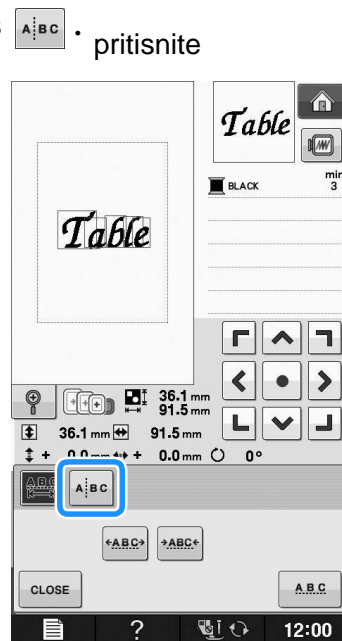

3   strelicama selektujte dizajn

koji želite da razdvojite i onda 
da ga razdvojite

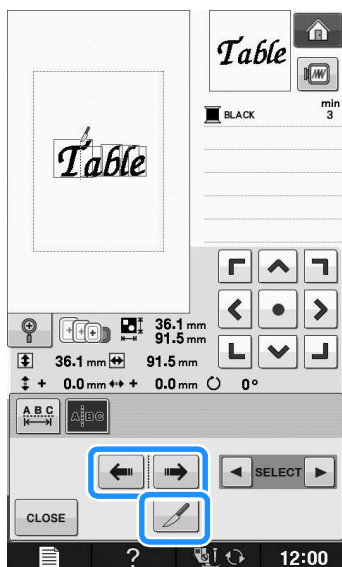

4   koristite strelice da selektujete

zatim  da podesite razmak

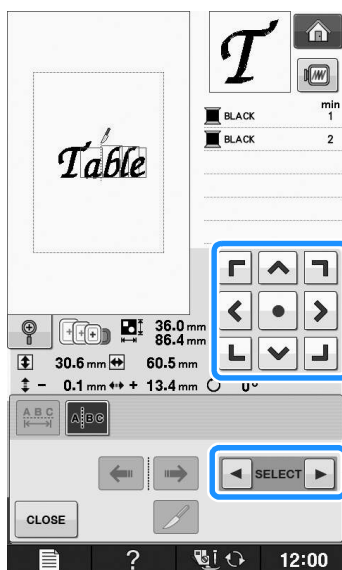

5  pritisnite

PROMENA BOJE SVAKOG SLOVA

1  pritisnite da možete da izaberete svaku boju

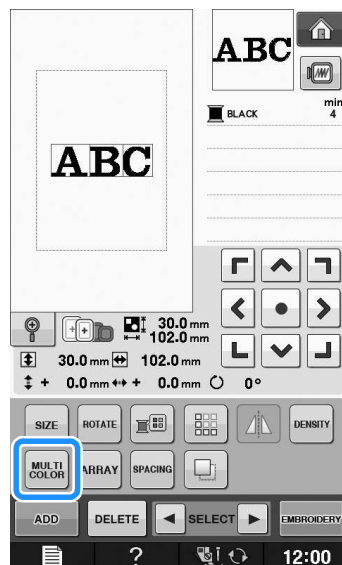

2 zamenite konac svaki put kada vezete novu boju

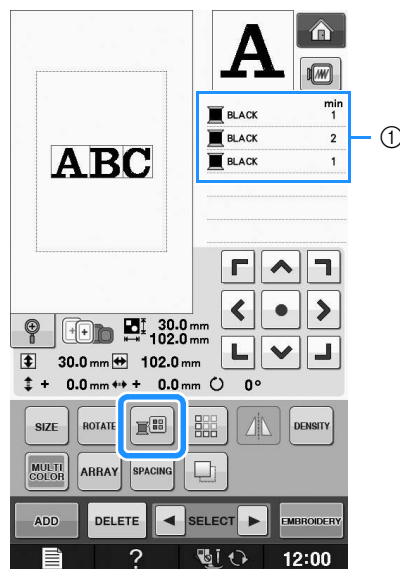

① boja

VEZ POVEZANIH KARAKTERA

primer:

povežite "DEF"
sa "ABC"

A B C D E F

ZAMENA BOJE



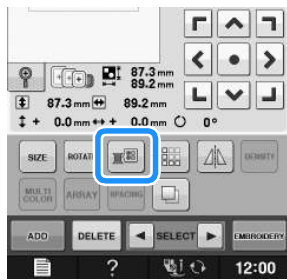

1 pritisnite 

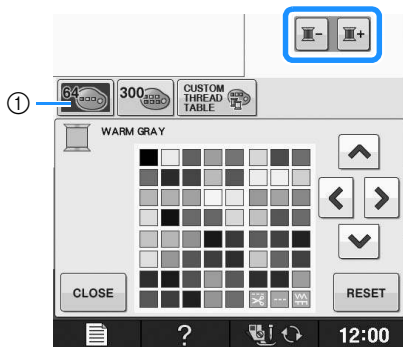

2 ili  ili  pritisnite za željenu boju



① 64 boja na tabli

3    
pritisnite strelice da izaberete novu boju

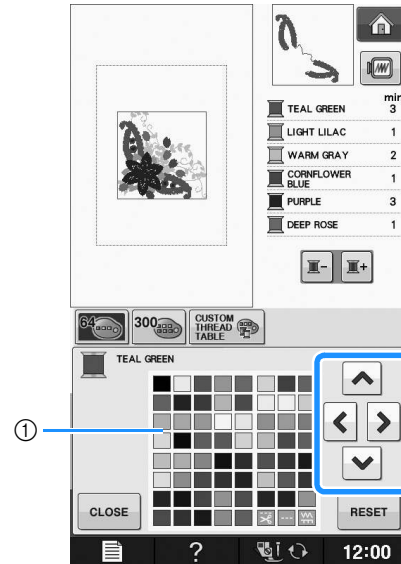

① paleta boja



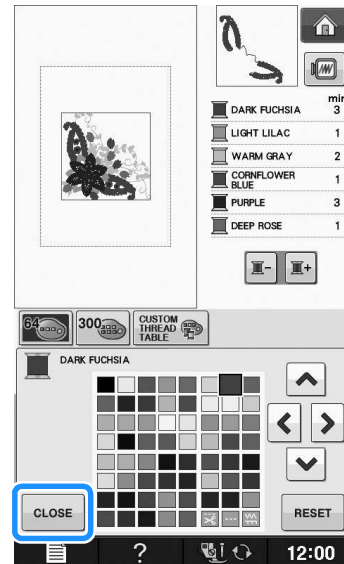

4  pritisnite



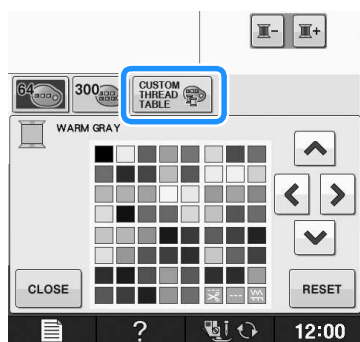

KREIRANJE UOBIČAJENE TABLE BOJA



- 1 u podešavanjima prvo pritisnite  a zatim .

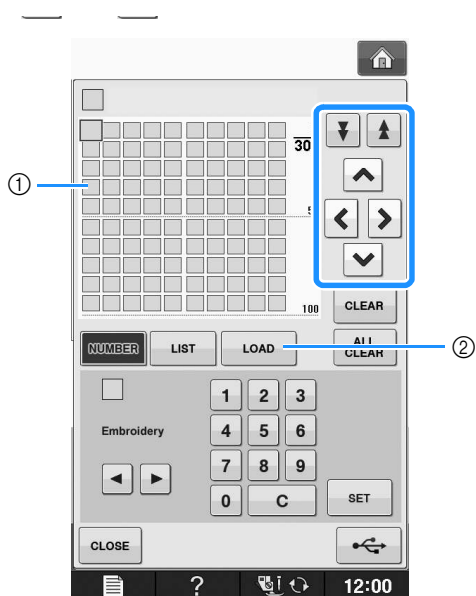









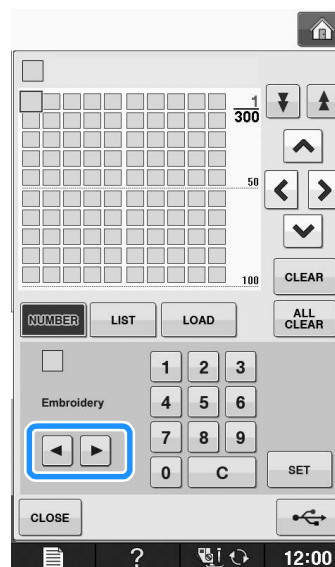

- 2     koristite strelice da izaberete gde da dodate novu boju na paleti



- ① uobičajena paleta boja
②  pritisnite da obustavite

- 3   koristite strelice da izaberete neki od brendova konca koji su ponuđeni



- 4        
 
ubacite četvorocifreni broj konca

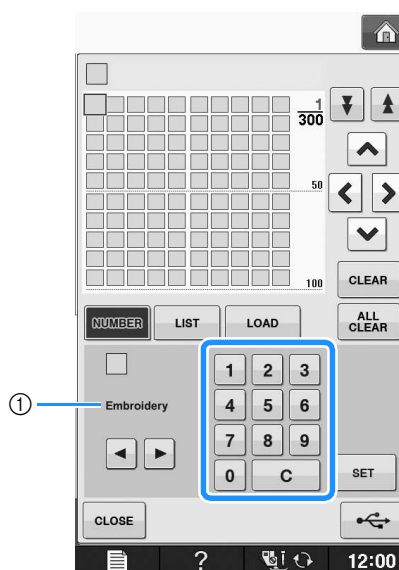

- ① brend

5

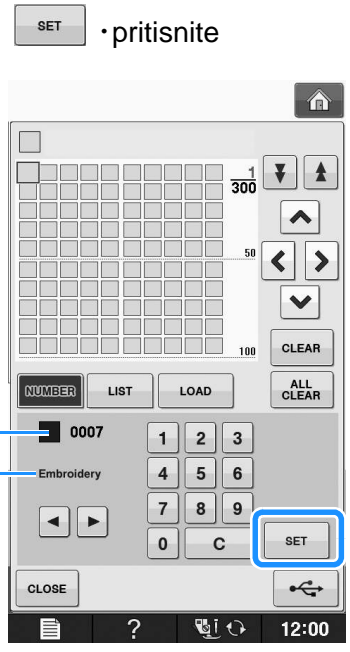

② 0007
① Embroidery

① brend
② ubačen broj

6

ponovite korake ispred, sve dok ne unesete sve željene boje

7

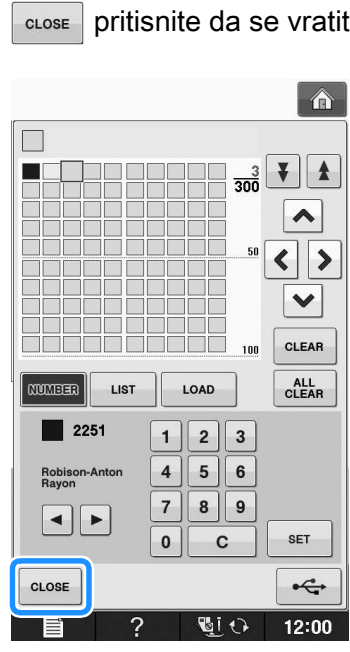

CLOSE pritisnite da se vratite na početni ekran

■ DODAVANJE BOJA NA UOBIČAJENU TABLU

1

ponovite korake od 1 do 3

2

LIST pritisnite da se pojavi lista

3

▲ ▼ pritisnite da selektujete boju

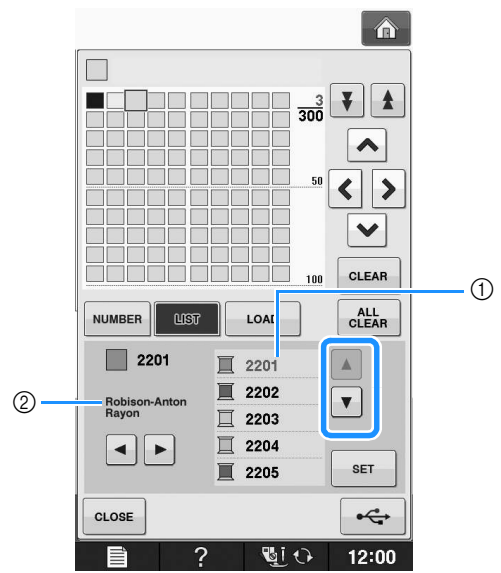

①
② Robison-Anton Rayon

① lista
② brend

4

SET pritisnite



E
2

Embroidery Edit

5 ponovite korake sve dok ne završite unošenje svih boja

6  pritisnite da se vratite na početnu stranu

■ ČUVANJE TABLE NA USBu

1 pritisnite  a zatim .

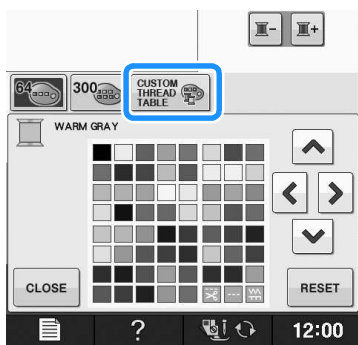

2 podesite željene boje na tabli

3 ubacite usb

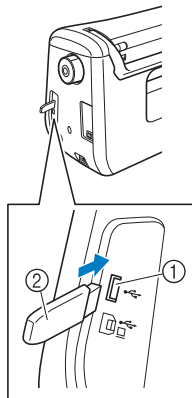

- ① ulaz
- ② USB

4  pritisnite

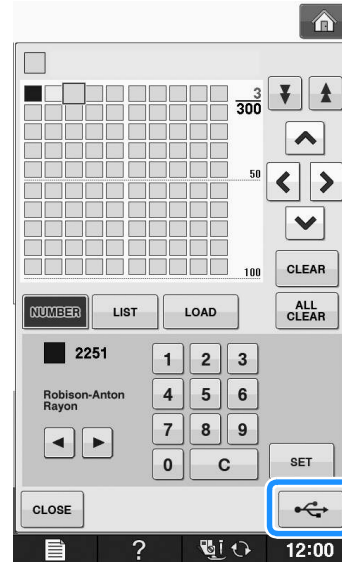

■ OPOZIVANJE TABLE SA PODEŠAVANJIMA SA USBa

postoji mogućnost da opozovete ovu funkciju

1 ubacite usb

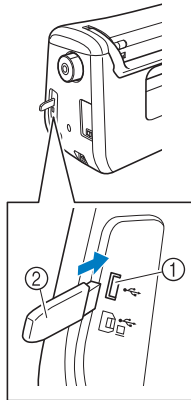

1 ulaz
2 USB

2 pritisnite a zatim .

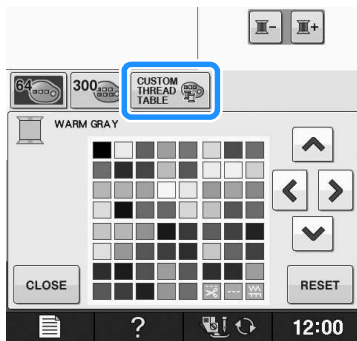

3 pritisnite

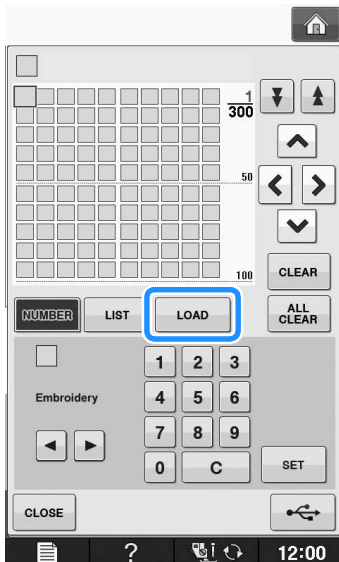

4 opozvana tabla se prikaže na ekranu

ODABIR BOJE SA TABLE

1 pritisnite

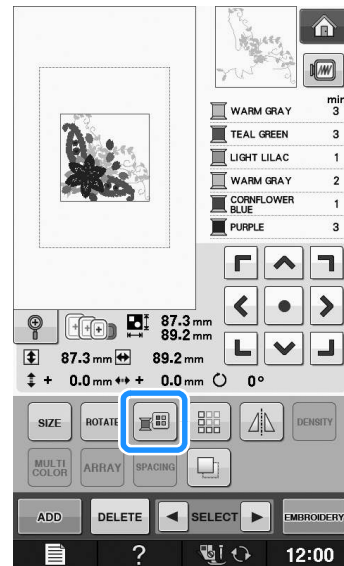

2 ili ovo ili pritisnite kada želite da izaberete boju

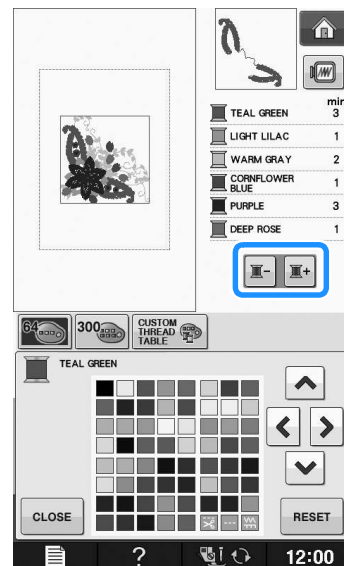

3

300 pritisnite

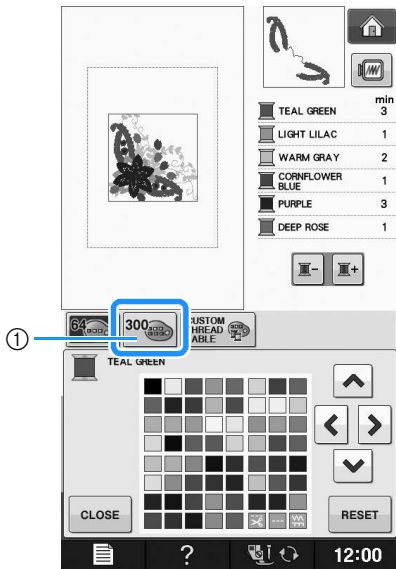

① uobičajena funkcija za promenu boja

4



poslužite se strelicama da izaberete novu boju

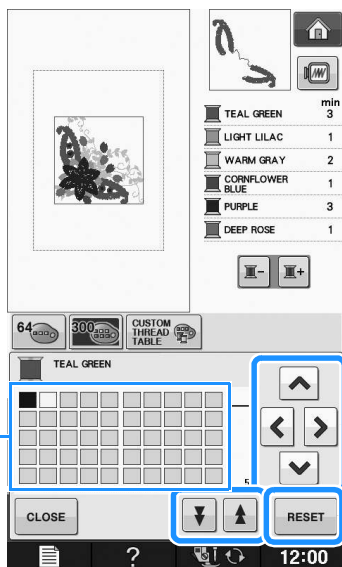

① uobičajena tabla

5

CLOSE pritisnite

PONAVLJANJE DIZAJNA

možete napraviti ramove za okvir, koristeći ponavljanje dizajna

1

izaberite dizajn i pritisnite .

2

pritisnite

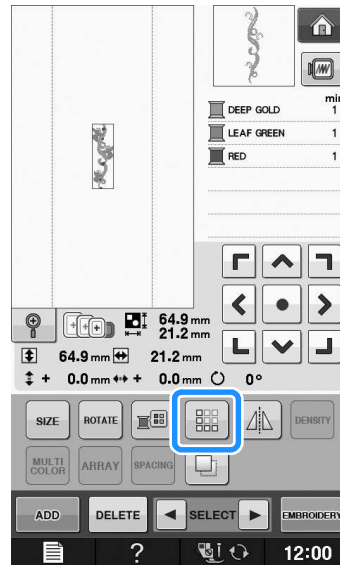

3

odaberite pravac kretanja

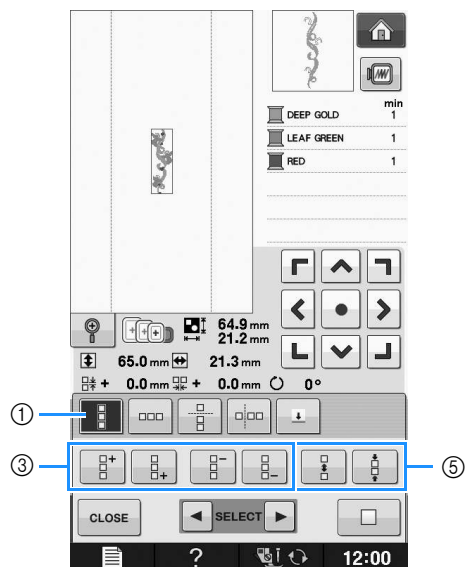

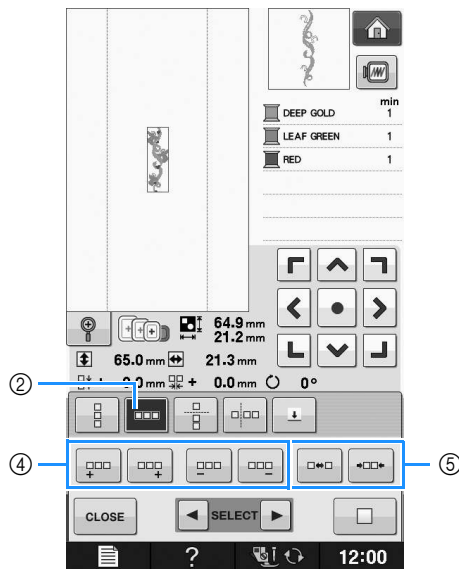

- ① vertikalno
- ② horizontalno
- ③ ponavljanje i brisanje vertikalnih funkcija
- ④ ponavljanje i brisanje horizontalnih funkcija
- ⑤ razmak

4 pritisnite da ponovite dizajn iznad, a

da ponovite dizajn ispod

da izbrisete iznad

da izbrisete ispod pritisnite

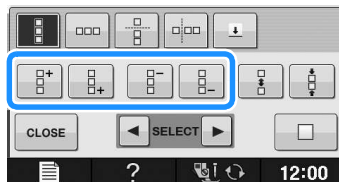

5 podešavanje razmaka

da povećate

da smanjite

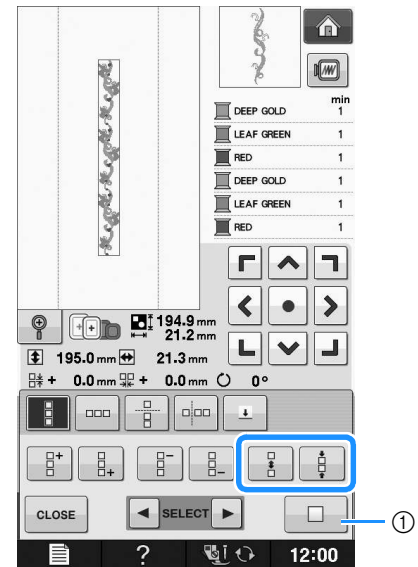

① pritisnite da promenite ponovljeni dizajn u pojedinačni

6 kompletirajte ponovljene dizajne praćenjem koraka od 3 do 5

7 pritisnite da završite operaciju

■ PONAVLJANJE SAMO JEDNOG ELEMENTA PONOVLJENOG DIZAJNA

1 izaberite pravac gde će element biti isečen

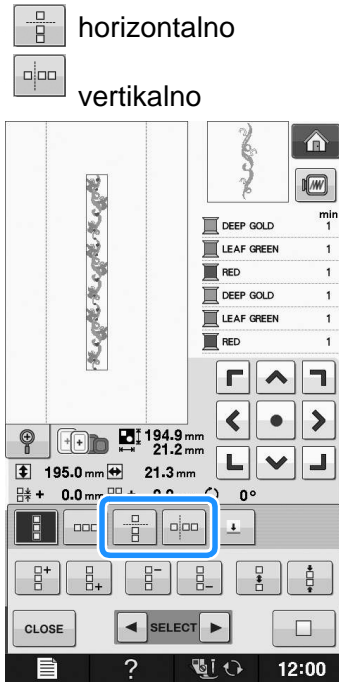



2 ili  ili  da selektujete liniju odreza

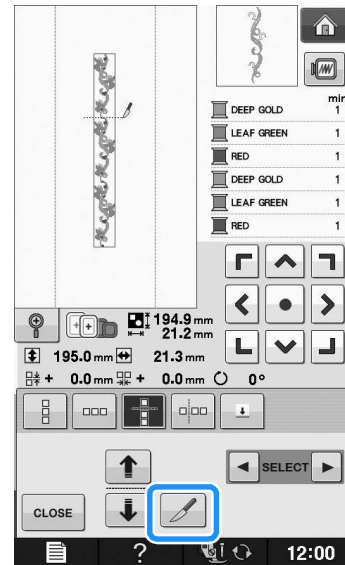

3  pritisnite



4  pritisnite

5 ili  ili  da selektujete element koji će se ponavljati

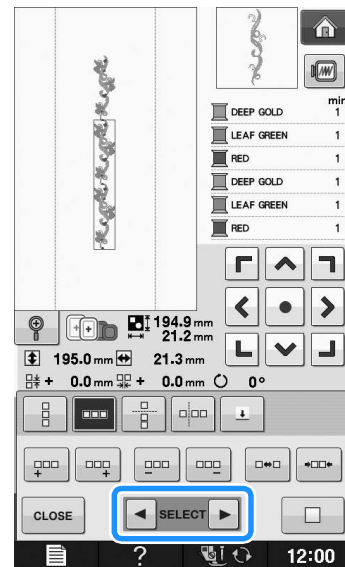

6 ponovite selektovani element

7

CLOSE pritisnite da završite ponavljanje

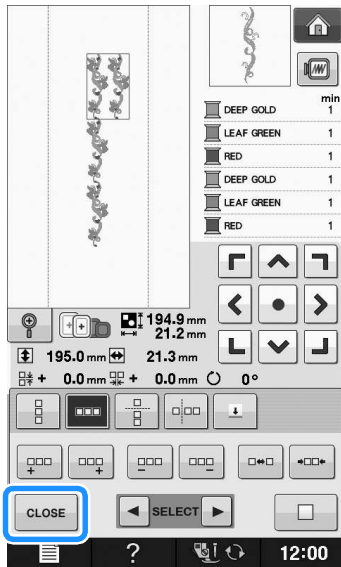

■ SORTIRANJE BOJA PONOVLJENIH ELEMENATA

EMBROIDERY pritisnite

da promenite boju

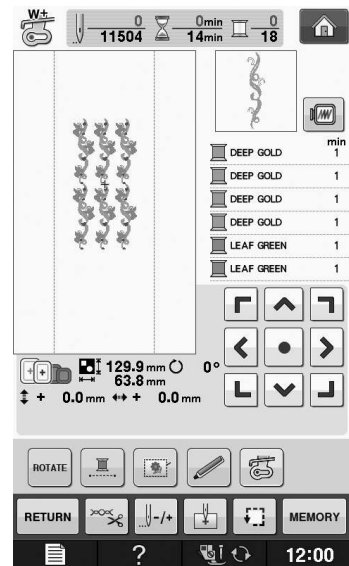
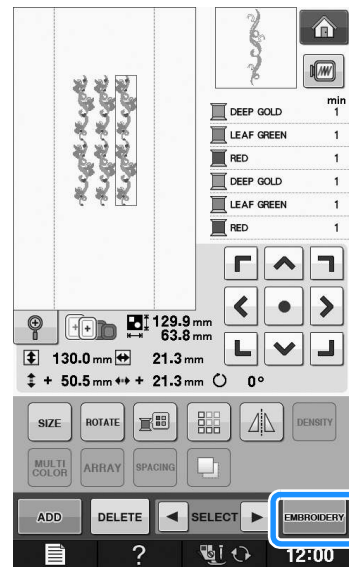

■ DODELJIVANJE OZNAKE KONCA

1  . pritisnite

2  . pritisnite

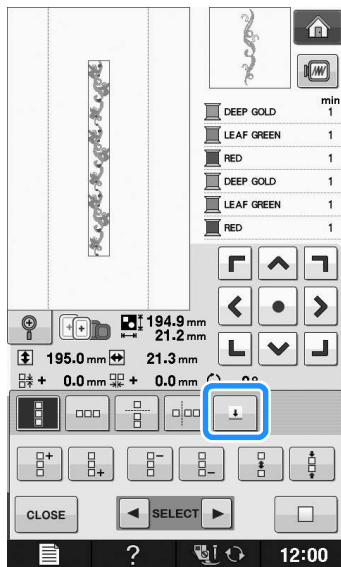

3  pritisnite

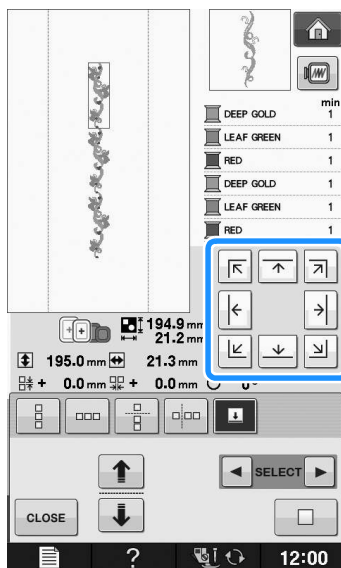

4  . pritisnite

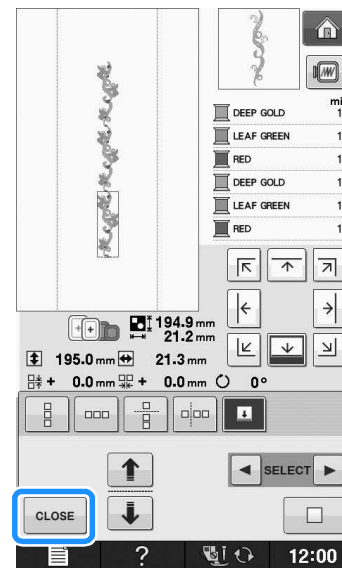

VEZ DIZAJNA U VIŠE NAVRATA

kada završite podešavanje ponovljenog dizajna, namestite materijal na ram i vezite u više navrata ako je potrebno

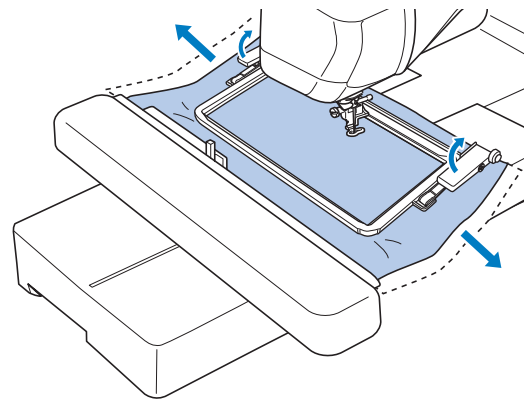

- 1 napravite ponovljeni dizajn sa koncem obeleženim u centru, na kraju dizajna

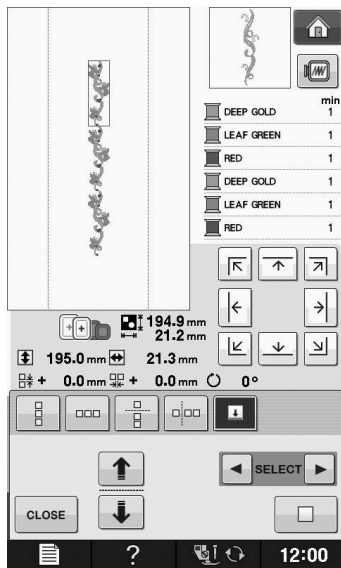

- 2 pritisnite , zatim .

- 3 pritisnite start stop dugme za vez



- 4 sklonite ram za vez

- 5 ponovo namestite materijal na ram za vez

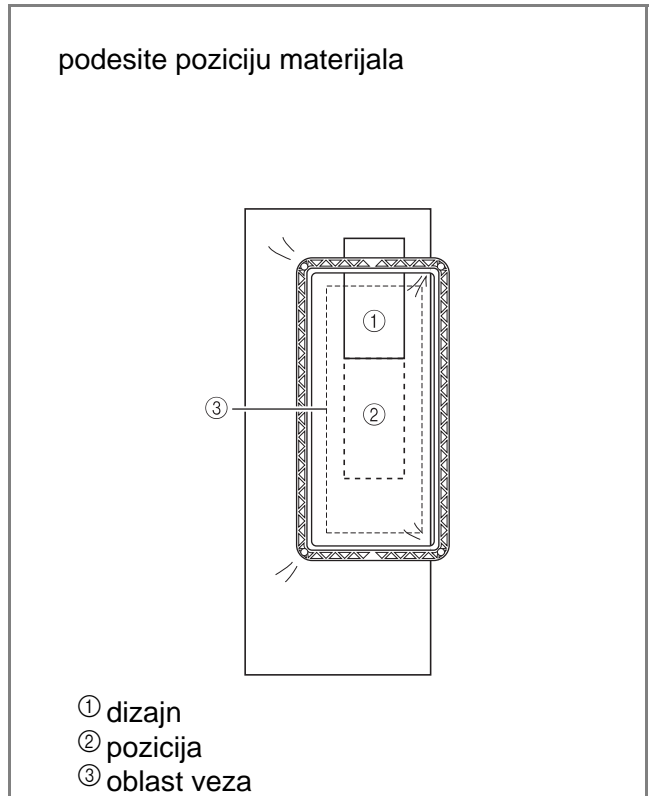

- 6 prikačite ram za vez, a zatim pritisnite .

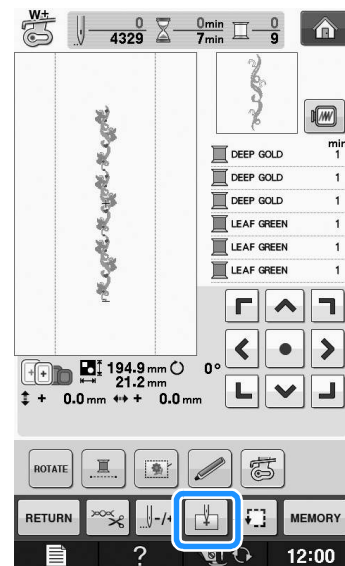

7 pritisnite  da podesite startnu poziciju

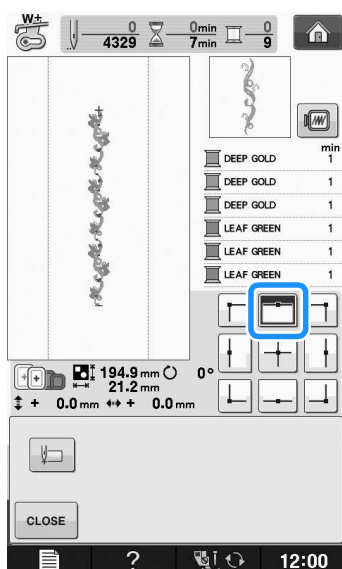

8 pritisnite .

9 pritisnite strelice za pomerenje, sve dok se ne izjednače ram i znak konca na materijalu

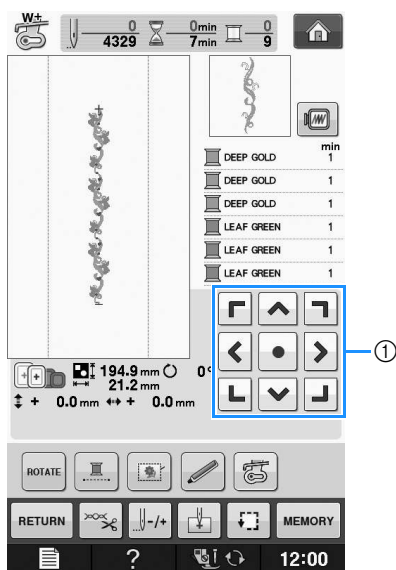

① strelice za pozicioniranje

10 uklonite oznaku

11 pritisnite start-stop da vezete

DUPLIKATI

1  pritisnite

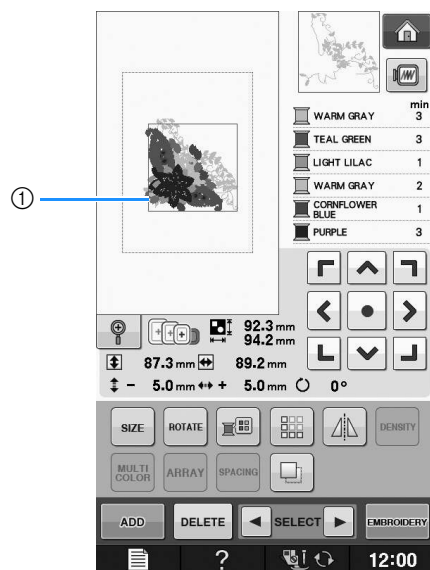
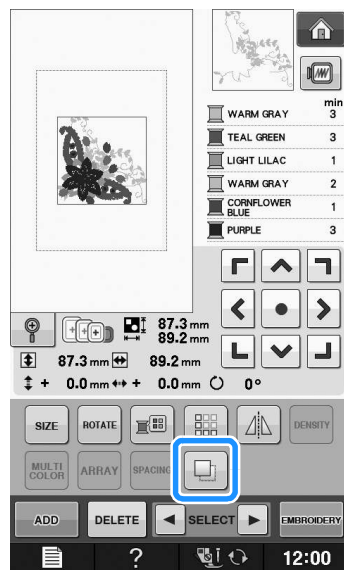

① duplicirani dizajn

POSLE PODEŠAVANJA

1

EMBROIDERY • pritisnite

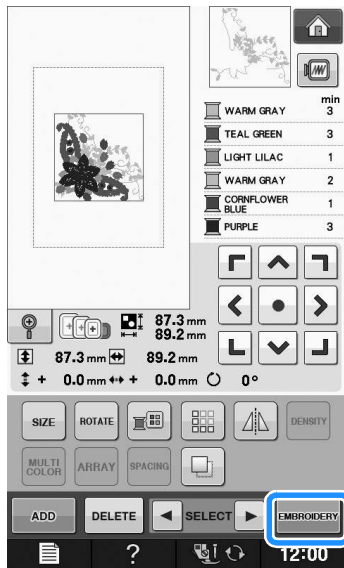

E
2

Embroidery Edit

KOMBINOVANJE DIZAJNA

podešavanja kombinovanog dizajna

Primer: slova i slika
-kombinacija



1



pritisnite da izaberete dizajn

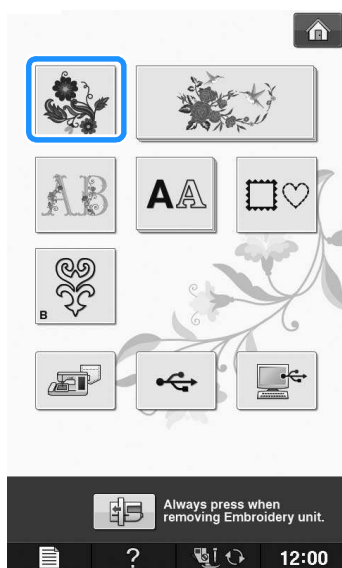

2



selektujte

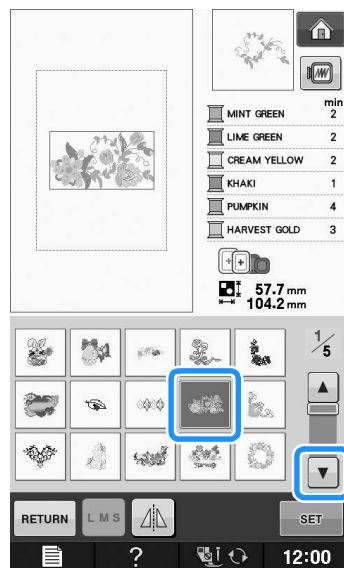

3

SET

pritisnite

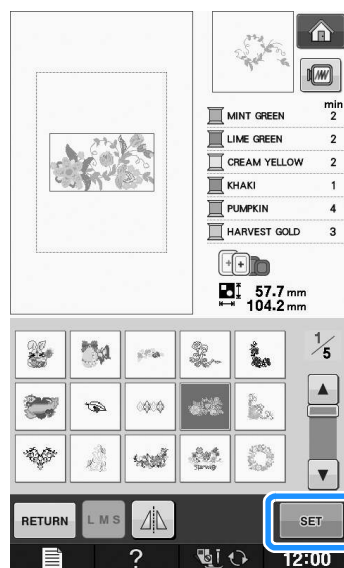

4 pritisnite **ADD**.

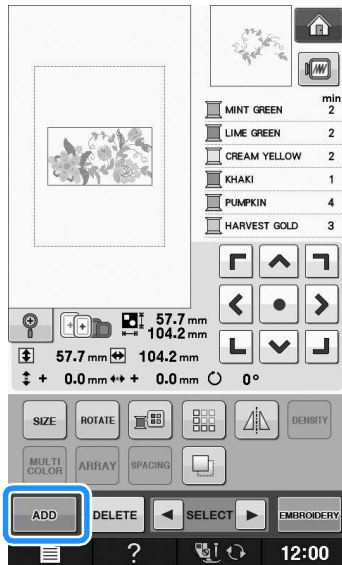

5 pritisnite **AA** da ubacite slova



6 selektujte **ABC** i ubacite "Flower".

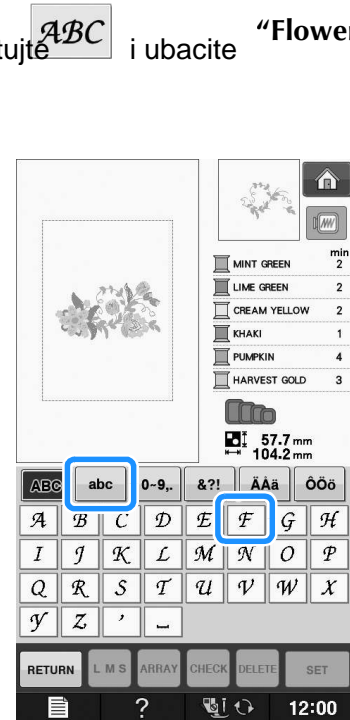

7 pritisnite **SET**.

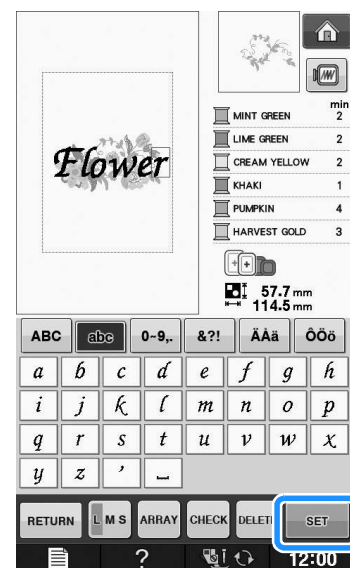

8 strelicama pomerajte karaktere



9 pritisnite **ARRAY** da promenite poziciju
a zatim **CLOSE**.

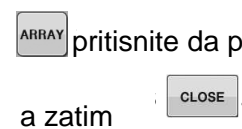

10

pritisnite da promenite boju karaktera

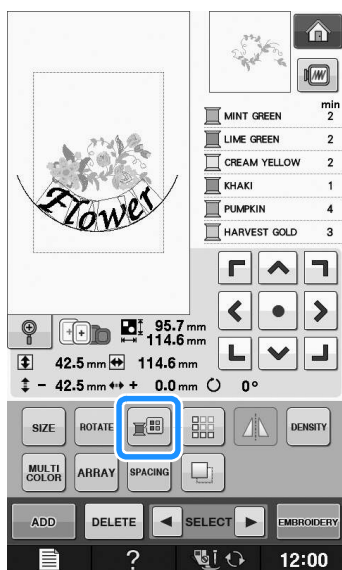

-strelice za selektovanje

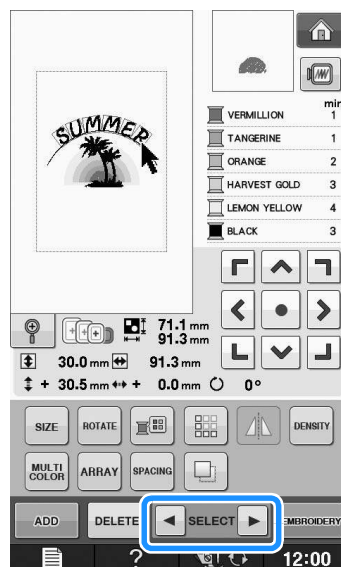

11

kada se sva podešavanja završe pritisnite

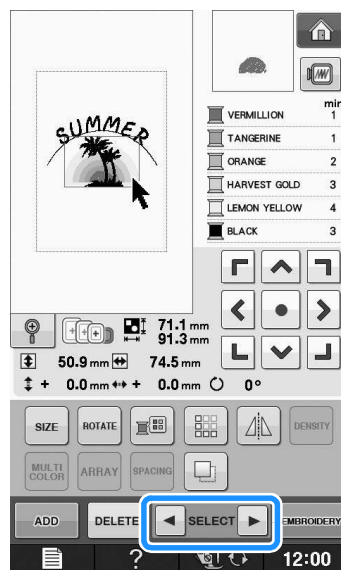
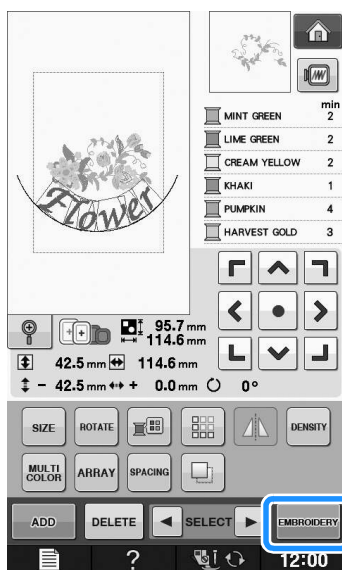

SELEKTOVANJE KOMBINOVANOG DIZAJNA ZA VEZ



koristite strelice da selektujete ono šta želite da podešavate

IZRADA KOMBINOVANIH DIZAJNA

kombinovani vez će biti izrađen po redu u kojem je izrađen primer:



1 vez se radi prateći boju na desnoj strani

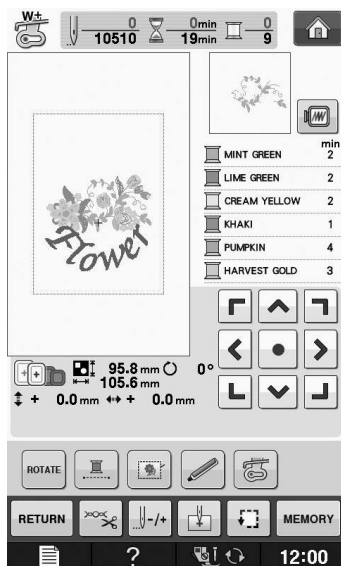

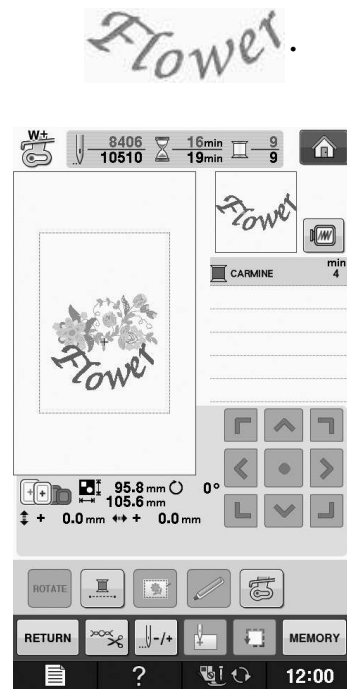

2 vez



RAZNE FUNKCIJE VEZA

VEZ U JEDNOJ BOJI; BEZ PREKIDANJA

vez može biti izrađen u jednoj boji pritiskom na 

 pritisnite da vratite

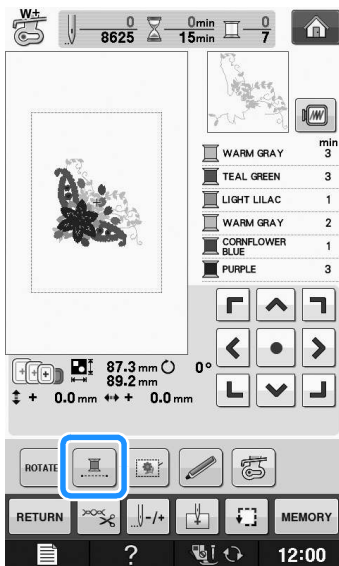



FIRC VEZ

ukoliko nemate stabilizator, firc vez će vam pomoći da pričvrstite materijal po ivicama

1

 pritisnite

2

koristeći  ili  pritisnite da precizirate distancu firc boda

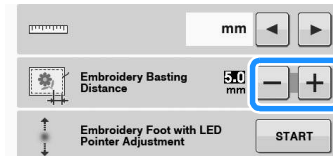

3

 pritisnite da se vratite na početni ekran

4

 pritisnite

5

 pritisnite da izaberete firc bod

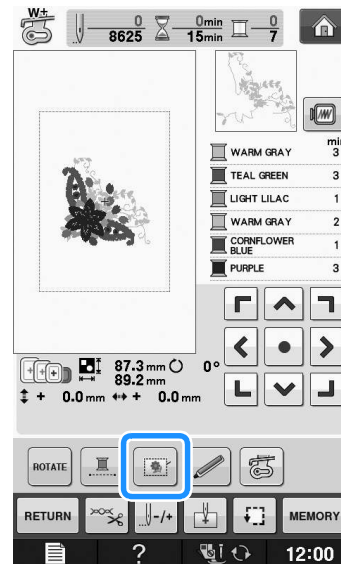

za promenu podešavanja pritisnite



6 pritisnite start stop da vezete

7 kada je vez gotov, uklonite firc bod

